

AIR CONDITIONER

3-unit multi-split type

SERVICE MANUAL

INDOOR



AUXG07KVLA
AUXG09KVLA
AUXG12KVLA
AUXG14KVLA
AUXG18KVLA



ARXG07KSLAP
ARXG09KSLAP
ARXG12KSLAP
ARXG14KSLAP
ARXG18KSLAP



ARXG07KLLAP
ARXG09KLLAP
ARXG12KLLAP
ARXG14KLLAP
ARXG18KLLAP



ASYG07KGTB
ASYG09KGTB
ASYG12KGTB
ASYG14KGTB



ASYG18KMTB



ASYG07KMCC
ASYG09KMCC
ASYG12KMCC
ASYG14KMCC



ASYG07KETA
ASYG09KETA
ASYG12KETA
ASYG14KETA



ASYG07KETA-B
ASYG09KETA-B
ASYG12KETA-B
ASYG14KETA-B



ABYG18KRTA



AGYG09KVCA
AGYG12KVCA
AGYG14KVCA

OUTDOOR



AOYG18KBTA3
AOYG24KBTA3

Notices:

- Product specifications and design are subject to change without notice for future improvement.
- For further details, please check with our authorized dealer.

Trademarks

FGLair™ is trademark of Fujitsu General Limited in the United States, other countries or both.

Google Play™ is trademark of Google Inc.

App Store® is a service mark of Apple Inc., registered in the U.S. and other countries.

CONTENTS

1. GENERAL INFORMATION

2. TECHNICAL DATA AND PARTS LIST

1. GENERAL INFORMATION

CONTENTS

1. GENERAL INFORMATION

1. Specifications	01-1
1-1. Indoor unit	01-1
1-2. Outdoor unit.....	01-13
2. Dimensions	01-15
2-1. Compact cassette type	01-15
2-2. Mini duct type	01-17
2-3. Slim duct type	01-20
2-4. Wall mounted type.....	01-23
2-5. Ceiling type.....	01-31
2-6. Floor type	01-33
2-7. Outdoor unit.....	01-35

1. Specifications

1-1. Indoor unit

■ Compact cassette type

Model name				AUXG07KVLA	AUXG09KVLA	AUXG12KVLA	AUXG14KVLA	
Power supply				1Ø 230 V ~50 Hz				
Available voltage range				198—264 V				
Capacity		kW class		2.0	2.5	3.5	4.0	
Input power		W		18		23	28	
Running current		A		0.15		0.19	0.22	
Fan	Airflow rate	Cooling	HIGH	m ³ /h	540	610	680	
			MED		490	530	580	
			LOW		440	470	490	
			QUIET		390	410	410	
		Heating	HIGH		540	610	790	
			MED		490	530	680	
			LOW		440	470	580	
			QUIET		390	410	450	
	Type × Q'ty		Turbo fan × 1					
	Motor output		W		54			
Sound pressure level *	Cooling	dB (A)	HIGH	33	37	38		
			MED	31	34	35		
			LOW	29	31	32		
			QUIET	27	28	29		
	Heating	HIGH	34	37	43			
		MED	32	34	38			
		LOW	29	31	34			
		QUIET	27	29	30			
Sound power level	Cooling	dB (A)	46	49	50			
	Heating		47	49	55			
Heat exchanger type	Dimensions (H × W × D)		mm	Main1: 210 × 1,310 × 13.3 Main2: 210 × 1,250 × 13.3				
	Fin pitch		mm	1.2				
	Rows × Stages			Main1: 1 × 10 Main2: 1 × 10				
	Pipe type			Copper tube				
	Fin type			Aluminum				
Dimensions (H × W × D)	Net		mm	245 × 570 × 570				
	Gross			265 × 730 × 625				
Weight	Net		kg	15				
	Gross			19				
Connection pipe	Size	Liquid	mm (in)	Ø6.35 (Ø1/4)				
		Gas		Ø9.52 (Ø3/8)				
	Method			Flare				
Drain hose	Material		PVC					
	Tip diameter		mm	Ø25 (I.D.), Ø32 (O.D.)				
Operation range	Cooling	°C	18 to 32					
		%RH	80 or less					
	Heating	°C	16 to 30					
Cassette grille (Grid type: Option)	Model name		UTG-UFYF-W					
	Material		Polystyrene					
	Color		White Approximate color of Munsell 9PB 9.1/0.2					
	Dimensions (H × W × D)	Net		mm	49 × 620 × 620			
		Gross			120 × 765 × 755			
	Weight	Net		kg	2.3			
Gross		4.5						

NOTES:

- The protective function might work when using it outside the operation range.
- *: Sound pressure level:
 - These are the measured values in the manufacturer's anechoic chamber.
 - Because of the surrounding sound environment, the sound levels measured in actual installation conditions might be higher than the specified values here.

Model name				AUXG18KVLA			
Power supply				1Ø 230 V ~50 Hz			
Available voltage range				198—264 V			
Capacity			kW class	5.0			
Input power				W			
Running current				A			
Fan	Airflow rate	Cooling	HIGH	m ³ /h	680		
			MED		580		
			LOW		490		
			QUIET		410		
		Heating	HIGH		790		
			MED		680		
			LOW		580		
			QUIET		450		
	Type × Q'ty			Turbo fan × 1			
	Motor output			W			
Sound pressure level *				dB (A)	54		
Cooling	HIGH	HIGH	38				
		MED	35				
		LOW	32				
		QUIET	29				
Heating	HIGH	HIGH	43				
		MED	38				
		LOW	34				
		QUIET	30				
Sound power level		Cooling	dB (A)	50			
		Heating		55			
Heat exchanger type		Dimensions (H × W × D)		mm	Main1: 210 × 1,310 × 13.3		
		Fin pitch			Main2: 210 × 1,250 × 13.3		
		Rows × Stages		Main1: 1 × 10			
		Pipe type		Main2: 1 × 10			
		Fin type		Copper tube			
Dimensions (H × W × D)		Net		mm	Aluminum		
		Gross			245 × 570 × 570		
Weight		Net		kg	265 × 730 × 625		
		Gross			15		
Connection pipe		Size	Liquid	mm (in)	Ø6.35 (Ø1/4)		
			Gas		Ø12.70 (Ø1/2)		
Drain hose		Method		Flare			
Operation range		Material		PVC			
		Tip diameter		mm			
		Cooling		°C			
		Heating		%RH			
				18 to 32			
				80 or less			
				16 to 30			
Cassette grille (Grid type: Option)		Model name		UTG-UFYF-W			
		Material		Polystyrene			
		Color		White			
				Approximate color of Munsell 9PB 9.1/0.2			
		Dimensions (H × W × D)		Net		mm	49 × 620 × 620
				Gross			120 × 765 × 755
Weight		Net		kg	2.3		
		Gross			4.5		
NOTES:							
<ul style="list-style-type: none"> • The protective function might work when using it outside the operation range. • *: Sound pressure level: <ul style="list-style-type: none"> – These are the measured values in the manufacturer's anechoic chamber. – Because of the surrounding sound environment, the sound levels measured in actual installation conditions might be higher than the specified values here. 							

■ Mini duct type

Model name			ARXG07KSLAP	ARXG09KSLAP	ARXG12KSLAP	ARXG14KSLAP		
Power supply			1Ø 230 V ~50 Hz					
Available voltage range			198—264 V					
Capacity			kW class	2.0	2.5	3.5	4.0	
Input power	Fan	HIGH	W	33	40	47	72	
		MED		23	23	26	44	
		LOW		20	20	22	30	
		QUIET		18	18	18	18	
Running current			A	0.29	0.33	0.38	0.58	
Fan	Airflow rate	Cooling	m ³ /h	HIGH	550	600	650	800
				MED	440	450	490	640
				LOW	390	400	430	530
				QUIET	360	360	360	360
		Heating		HIGH	550	600	650	800
				MED	440	450	490	640
				LOW	390	400	430	530
				QUIET	360	360	360	360
	Type × Q'ty			Sirocco fan × 2				
	Motor output			W	75			
Recommended static pressure			Pa	0 to 30			0 to 50	
Sound pressure level *	Cooling	HIGH	dB (A)	29	29	31	35	
		MED		26	26	27	30	
		LOW		24	24	25	27	
		QUIET		23	23	23	23	
	Heating	HIGH		29	29	31	35	
		MED		26	26	27	30	
		LOW		24	24	25	27	
		QUIET		23	23	23	23	
Sound power level	Cooling	dB (A)	52	54	55	60		
	Heating		53	56	57	62		
Heat exchanger type	Dimensions (H × W × D)		mm	336 × 490 × 26.6				
	Fin pitch		mm	1.3				
	Rows × Stages			2 × 16				
	Pipe type			Copper tube				
	Fin type			Aluminum				
Enclosure	Material			Steel sheet				
	Color			—				
Dimensions (H × W × D)	Net		mm	198 × 700 × 450				
	Gross			250 × 930 × 580				
Weight	Net		kg	15.5				
	Gross			19.0				
Connection pipe	Size	Liquid	mm (in)	Ø6.35 (Ø1/4)				
		Gas		Ø9.52 (Ø3/8)				
	Method			Flare				
Drain hose	Material			Hard PVC				
	Tip diameter		mm	Ø25 (I.D.), Ø32 (O.D.)				
Operation range	Cooling	°C	18 to 32					
		%RH	80 or less					
	Heating	°C	16 to 30					

NOTES:

- Values mentioned in the table are based on the following conditions:
 - Static pressure: 10 Pa
- The protective function might work when using it outside the operation range.
- *: Sound pressure level:
 - These are the measured values in the manufacturer's anechoic chamber.
 - Because of the surrounding sound environment, the sound levels measured in actual installation conditions might be higher than the specified values here.

Model name				ARXG18KSLAP		
Power supply				1Ø 230 V ~ 50 Hz		
Available voltage range				198—264 V		
Capacity			kW class	5.0		
Input power	Fan	HIGH	W	63		
		MED		38		
		LOW		22		
		QUIET		19		
Running current			A	0.49		
Fan	Airflow rate	Cooling	HIGH	m ³ /h	940	
			MED		750	
			LOW		540	
			QUIET		480	
		Heating	HIGH		940	
			MED		750	
			LOW		540	
			QUIET		480	
	Type × Q'ty		Sirocco fan × 3			
	Motor output			W	80	
Recommended static pressure			Pa	0 to 50		
Sound pressure level *	Cooling	HIGH	dB (A)	33		
		MED		29		
		LOW		26		
		QUIET		23		
	Heating	HIGH		33		
		MED		29		
		LOW		26		
		QUIET		23		
Sound power level	Cooling	dB (A)		58		
	Heating			59		
Heat exchanger type	Dimensions (H × W × D)		mm	336 × 690 × 26.6		
	Fin pitch			1.30		
	Rows × Stages			2 × 16		
	Pipe type			Copper tube		
	Fin type			Aluminum		
Enclosure	Material		Steel sheet			
	Color		—			
Dimensions (H × W × D)	Net		mm	198 × 900 × 450		
	Gross			250 × 1,130 × 580		
Weight	Net		kg	18.5		
	Gross			23.0		
Connection pipe	Size	Liquid	mm (in)	Ø6.35 (Ø1/4)		
		Gas		Ø12.7 (Ø1/2)		
	Method			Flare		
Drain hose	Material		PVC			
	Tip diameter		mm	Ø25 (I.D.), Ø32 (O.D.)		
Operation range	Cooling	°C		18 to 32		
		%RH		80 or less		
	Heating	°C		16 to 30		

NOTES:

- Values mentioned in the table are based on the following conditions:
 - Static pressure: 15 Pa
- The protective function might work when using it outside the operation range.
- *: Sound pressure level:
 - These are the measured values in the manufacturer's anechoic chamber.
 - Because of the surrounding sound environment, the sound levels measured in actual installation conditions might be higher than the specified values here.

■ Slim duct type

Model name			ARXG07KLLAP	ARXG09KLLAP	ARXG12KLLAP	ARXG14KLLAP	
Power supply			1Ø 230 V ~50 Hz				
Available voltage range			198—264 V				
Capacity	kW class		2.0	2.5	3.5	4.0	
Input power	W		33	49	58	76	
Running current	A		0.33	0.30	0.35	0.51	
Fan	Airflow rate	Cooling	HIGH	550	600	650	800
			MED	490	550	600	700
			LOW	470	500	550	600
			QUIET	440	450	480	480
		Heating	HIGH	550	600	650	800
			MED	490	550	600	700
			LOW	470	500	550	600
			QUIET	440	450	480	480
	Type × Q'ty		Sirocco fan × 2				
	Motor output		W	80	81		
Recommended static pressure			Pa			0 to 90	
Sound pressure level *	Cooling	HIGH	28	28	29	32	
		MED	26	27	28	30	
		LOW	25	26	27	28	
		QUIET	24	25	26	26	
	Heating	HIGH	28	28	29	32	
		MED	26	26	28	30	
		LOW	25	25	27	28	
		QUIET	24	24	24	25	
Sound power level	Cooling	dB (A)		57	58	60	
	Heating			57	58	60	
Heat exchanger type	Dimensions (H × W × D)		mm	294 × 500 × 26.6	294 × 500 × 39.9		
	Fin pitch		mm	1.3			
	Rows × Stages			2 × 14	3 × 14		
	Pipe type		Copper tube				
	Fin type		Aluminum				
Enclosure	Material	Steel sheet					
	Color	—					
Dimensions (H × W × D)	Net	mm		198 × 700 × 620			
	Gross	276 × 968 × 772					
Weight	Net	kg		16	17		
	Gross	21					
Connection pipe	Size	Liquid	mm (in)			Ø6.35 (Ø1/4)	
		Gas				Ø9.52 (Ø3/8)	
	Method	Flare					
Drain hose	Material	PVC					
	Tip diameter	mm		Ø25 (I.D.), Ø32 (O.D.)			
Operation range	Cooling	°C		18 to 32			
		%RH		80 or less			
	Heating	°C		16 to 30			
NOTES:							
<ul style="list-style-type: none"> • Values mentioned in the table are based on the following conditions: <ul style="list-style-type: none"> – Static pressure: 25 Pa • The protective function might work when using it outside the operation range. • *: Sound pressure level: <ul style="list-style-type: none"> – These are the measured values in the manufacturer's anechoic chamber. – Because of the surrounding sound environment, the sound levels measured in actual installation conditions might be higher than the specified values here. 							

Model name				ARXG18KLLAP		
Power supply				1Ø 230 V ~50 Hz		
Available voltage range				198—264 V		
Capacity			kW class	5.0		
Input power				W	73	
Running current				A	0.44	
Fan	Airflow rate	Cooling	HIGH	m ³ /h	940	
			MED		880	
			LOW		820	
			QUIET		750	
		Heating	HIGH		940	
			MED		880	
			LOW		820	
			QUIET		750	
	Type × Q'ty		Sirocco fan × 3			
	Motor output			W	81	
Recommended static pressure				Pa	0 to 90	
Sound pressure level *	Cooling	HIGH	dB (A)	32		
		MED		30		
		LOW		29		
		QUIET		27		
	Heating	HIGH		32		
		MED		30		
		LOW		29		
		QUIET		27		
Sound power level		Cooling	dB (A)	58		
		Heating		58		
Heat exchanger type	Dimensions (H × W × D)		mm	294 × 700 × 39.9		
	Fin pitch		mm	1.3		
	Rows × Stages		3 × 14			
	Pipe type		Copper tube			
	Fin type		Aluminum			
Enclosure	Material			Steel sheet		
	Color			—		
Dimensions (H × W × D)	Net		mm	198 × 900 × 620		
	Gross			276 × 1,168 × 772		
Weight	Net		kg	20		
	Gross			26		
Connection pipe	Size	Liquid	mm (in)	Ø6.35 (Ø1/4)		
		Gas		Ø12.70 (Ø1/2)		
	Method		Flare			
Drain hose	Material			PVC		
	Tip diameter		mm	Ø25 (I.D.), Ø32 (O.D.)		
Operation range	Cooling	°C		18 to 32		
		%RH		80 or less		
	Heating	°C		16 to 30		
NOTES:						
<ul style="list-style-type: none"> • Values mentioned in the table are based on the following conditions: <ul style="list-style-type: none"> – Static pressure: 25 Pa • The protective function might work when using it outside the operation range. • *: Sound pressure level: <ul style="list-style-type: none"> – These are the measured values in the manufacturer's anechoic chamber. – Because of the surrounding sound environment, the sound levels measured in actual installation conditions might be higher than the specified values here. 						

Wall mounted type

Model name			ASYG07KGTB	ASYG09KGTB	ASYG12KGTB	ASYG14KGTB	
Power supply			1Ø 230 V ~50 Hz				
Available voltage range			198—264 V				
Capacity	kW class		2.0	2.5	3.5	4.0	
Input power	W		23	27	27	33	
Running current	A		0.20	0.24	0.24	0.29	
Fan	Airflow rate	Cooling	HIGH	650	700	700	770
			MED	540	560	560	600
			LOW	430	430	430	450
			QUIET	270	270	270	280
		Heating	HIGH	720	750	770	800
			MED	580	610	640	660
			LOW	460	470	520	520
			QUIET	330	330	330	340
	Type × Q'ty		Crossflow fan × 1				
	Motor output		W	30		49	
Sound pressure level *1	Cooling	dB (A)	HIGH	38	40	40	43
			MED	33	34	35	36
			LOW	29	29	30	30
			QUIET	21	21	21	21
	Heating	HIGH	41	42	42	44	
		MED	35	36	38	39	
		LOW	31	31	33	33	
		QUIET	22	22	22	24	
Sound power level	Cooling	dB (A)	54	55	56	57	
	Heating		56	57	58	59	
Heat exchanger type	Dimensions (H × W × D)		mm		Main1: 210 × 670 × 26.6 Main2: 112 × 670 × 20.0		
	Fin pitch		mm		Main1: 1.2, Main2: 1.1		
	Rows × Stages				Main1: 2 × 10, Main2: 2 × 7		
	Pipe type				Copper tube		
Fin type				Aluminum			
Enclosure	Material				Polystyrene		
	Color				White + Pearl white (painted) Approximate color of Munsell N 9.25/		
Dimensions (H × W × D)	Net	mm	270 × 834 × 215				
	Gross		277 × 914 × 332				
Weight	Net	kg	10.0				
	Gross		12.5		13.0		
Connection pipe	Size	Liquid Gas	mm (in)	Ø6.35 (Ø1/4)			
				Ø9.52 (Ø3/8)			
Drain hose	Method		Flare				
	Material		PP + HDPE				
Operation range	Tip diameter		mm		Ø13.8 (I.D.), Ø15.0 to Ø16.8 (O.D.)		
	Cooling	°C	18 to 32				
%RH		80 or less					
Heating	°C	16 to 30					
	Remote controller type						
Wireless (Option: Wired, Mobile app*2 [FGLair™])							
NOTES:							
<ul style="list-style-type: none"> The protective function might work when using it outside the operation range. *1: Sound pressure level: <ul style="list-style-type: none"> These are the measured values in the manufacturer's anechoic chamber. Because of the surrounding sound environment, the sound levels measured in actual installation conditions might be higher than the specified values here. *2: Available on Google Play™ store or on App Store®. Optional WLAN adapter is also required. For details, refer to the setting manual. 							

Model name				ASYG18KMTB		
Power supply				1Ø 230 V ~50 Hz		
Available voltage range				198—264 V		
Capacity			kW class		5.0	
Input power				W		37.5
Running current				A		0.35
Fan	Airflow rate	Cooling	HIGH	m ³ /h	980	
			MED		810	
			LOW		640	
			QUIET		510	
		Heating	HIGH		1,020	
			MED		850	
			LOW		640	
			QUIET		510	
	Type × Q'ty			Crossflow fan × 1		
	Motor output			W		59
Sound pressure level *1	Cooling	HIGH	dB (A)	45		
		MED		40		
		LOW		35		
		QUIET		29		
	Heating	HIGH		46		
		MED		40		
		LOW		35		
		QUIET		29		
Sound power level	Cooling	dB (A)		60		
	Heating	dB (A)		61		
Heat exchanger type	Dimensions (H × W × D)		mm	Main1: 210 × 798 × 26.6 Main2: 135 × 798 × 20.0 Sub1: 84 × 798 × 13.3 Sub2: 84 × 798 × 13.3		
	Fin pitch		mm	Main1: 1.2, Main2: 1.1 Sub1: 1.4, Sub2: 1.4		
	Rows × Stages			Main1: 2 × 10 Main2: 2 × 8 Sub1: 1 × 4 Sub2: 1 × 4		
	Pipe type			Copper tube		
	Fin type			Aluminum		
	Material			Polystyrene		
Enclosure				White Approximate color of Munsell N 9.25/		
Dimensions (H × W × D)	Net		mm	280 × 980 × 240		
	Gross			322 × 1,078 × 346		
Weight	Net		kg	12.5		
	Gross			18		
Connection pipe	Size	Liquid	mm (in)	Ø6.35 (Ø1/4)		
		Gas		12.7 (Ø1/2)		
	Method			Flare		
Drain hose				PP + HDPE		
Tip diameter			mm	Ø13.8 (I.D.), Ø15.8 to Ø16.7 (O.D.)		
Operation range	Cooling	°C		18 to 32		
		%RH		80 or less		
	Heating	°C		16 to 30		
Remote controller type				Wireless (Option: Wired, Mobile app*2 [FGLair™])		
NOTES:						
<ul style="list-style-type: none"> • The protective function might work when using it outside the operation range. • *1: Sound pressure level: <ul style="list-style-type: none"> – These are the measured values in the manufacturer's anechoic chamber. – Because of the surrounding sound environment, the sound levels measured in actual installation conditions might be higher than the specified values here. • *2: Available on Google Play™ store or on App Store®. Optional WLAN adapter is also required. For details, refer to the setting manual. 						

Model name				ASYG07KMCC	ASYG09KMCC	ASYG12KMCC	ASYG14KMCC	
Power supply				1Ø 230 V ~50 Hz				
Available voltage range				198—264 V				
Capacity			kW class	2.0	2.5	3.5	4.0	
Input power				W	23	27	33	
Running current				A	0.20	0.24	0.30	
Fan	Airflow rate	Cooling	HIGH	m ³ /h	650	700	700	770
			MED		540	560	560	600
			LOW		430	430	430	450
			QUIET		320	320	320	310
		Heating	HIGH		720	750	780	820
			MED		580	610	640	660
			LOW		460	470	520	520
			QUIET		330	330	330	340
	Type × Q'ty		Crossflow fan × 1					
	Motor output			W	27			
Sound pressure level *1	Cooling	HIGH	dB (A)	38	40	40	43	
		MED		33	34	35	36	
		LOW		29	29	30	30	
		QUIET		21	21	21	21	
	Heating	HIGH		41	42	42	44	
		MED		35	36	38	39	
		LOW		31	31	33	33	
		QUIET		22	22	22	24	
Heat exchanger type	Dimensions (H × W × D)		mm	Main1: 210 × 670 × 26.6 Main2: 112 × 670 × 20			Main1: 210 × 670 × 26.6 Main2: 112 × 670 × 20 Sub: 84 × 670 × 13.3	
	Fin pitch			Man1: 1.2, Main2: 1.1			Man1: 1.2, Main2: 1.1, Sub: 1.4	
	Rows × Stages		Main1: 2 × 10, Main2: 2 × 7			Main1: 2 × 10, Main2: 2 × 7, Sub: 1 × 4		
	Pipe type		Copper tube					
	Fin type		Aluminum					
Enclosure	Material		Polystyrene					
	Color		White + Pearl white (painted) Approximate color of Munsell N 9.25/					
Dimensions (H × W × D)	Net		mm	270 × 834 × 222				
	Gross			277 × 914 × 332				
Weight	Net		kg	10.0				
	Gross			12.5			13.0	
Connection pipe	Size	Liquid	mm (in)	Ø6.35 (Ø1/4)				
		Gas		Ø9.52 (Ø3/8)				
Drain hose	Method		Flare					
	Material		PP + HDPE					
Operation range	Tip diameter		mm	Ø13.8 (I.D.), Ø15.0 to Ø16.8 (O.D.)				
	Cooling			°C		18 to 32		%RH
Remote controller type	Heating		°C		16 to 30			
	Wireless (Wired, Mobile app*2 [FGLair™] [option])							
NOTES:								
<ul style="list-style-type: none"> The protective function might work when using it outside the operation range. *1: Sound pressure level: <ul style="list-style-type: none"> These are the measured values in the manufacturer's anechoic chamber. Because of the surrounding sound environment, the sound levels measured in actual installation conditions might be higher than the specified values here. *2: Available on Google Play™ store or on App Store®. Optional WLAN adapter is also required. For details, refer to the setting manual. 								

Model name			ASYG07KETA ASYG07KETA-B	ASYG09KETA ASYG09KETA-B	ASYG12KETA ASYG12KETA-B	ASYG14KETA ASYG14KETA-B	
Power supply			1Ø 230 V ~50 Hz				
Available voltage range			198—264 V				
Capacity		kW class	2.0	2.5	3.5	4.0	
Input power		W	23	27	27	33	
Running current		A	0.20	0.24	0.24	0.30	
Fan	Airflow rate	Cooling	HIGH	650	700	700	770
			MED	540	560	560	600
			LOW	430	430	430	450
			QUIET	270	270	270	280
		Heating	HIGH	720	750	770	800
			MED	580	610	640	660
			LOW	460	470	520	520
			QUIET	330	330	330	340
	Type × Q'ty		Crossflow fan × 1				
	Motor output		W	30			49
Sound pressure level *1	Cooling	dB (A)	HIGH	38	40	40	43
			MED	33	34	35	36
			LOW	29	29	30	30
			QUIET	21	21	21	21
	Heating	HIGH	41	42	42	44	
		MED	35	36	38	39	
		LOW	31	31	33	33	
		QUIET	22	22	22	24	
Sound power level		dB (A)	54	55	55	57	
			56	57	58	59	
Heat exchanger type	Dimensions (H × W × D)		mm	Main1: 210 × 670 × 26.6 Main2: 112 × 670 × 20.0		Main1: 210 × 670 × 26.6 Main2: 112 × 670 × 20.0 Sub: 84 × 670 × 13.3	
	Fin pitch		mm	Main1: 1.2, Main2: 1.1		Main1: 1.2, Main2: 1.1 Sub: 1.4	
	Rows × Stages			Main1: 2 × 10, Main2: 2 × 7		Main1: 2 × 10 Main2: 2 × 7 Sub: 1 × 4	
	Pipe type			Copper tube			
	Fin type			Aluminum			
Enclosure	Material		Polystyrene				
	Color		KETA; White + Pearl white (painted) Approximate color of Munsell N 9.25/ KETA-B; Dark Gray + Silver (painted) Approximate color of Munsell 0.5P 3.5/0.2				
Dimensions (H × W × D)	Net	mm	295 × 950 × 230				
	Gross		284 × 1,027 × 357				
Weight	Net	kg	11.0		11.5		
	Gross		14.5		15.0		
Connection pipe	Size	mm (in)	Ø6.35 (Ø1/4)				
	Liquid Gas		Ø9.52 (Ø3/8)				
Drain hose	Method		Flare				
	Material		PP + HDPE				
Operation range	Tip diameter		Ø13.8 (I.D.), Ø15.0 to Ø16.8 (O.D.)				
	Cooling	°C	18 to 32				
%RH		80 or less					
Heating		°C	16 to 30				
Remote controller type			Wireless (Option: Wired, Mobile app*2 [FGLair™])				
NOTES:							
<ul style="list-style-type: none"> The protective function might work when using it outside the operation range. *1: Sound pressure level: <ul style="list-style-type: none"> These are the measured values in the manufacturer's anechoic chamber. Because of the surrounding sound environment, the sound levels measured in actual installation conditions might be higher than the specified values here. *2: Available on Google Play™ store or on App Store®. Optional WLAN adapter is also required. For details, refer to the setting manual. 							

■ Ceiling type

Model name			ABYG18KRTA			
Power supply			1Ø 230 V ~50 Hz			
Available voltage range			198—264 V			
Capacity		kW class	5.0			
Input power		W	37			
Running current		A	0.21			
Fan	Airflow rate	Cooling	HIGH	m ³ /h	840	
			MED		790	
			LOW		710	
			QUIET		650	
		Heating	HIGH		840	
			MED		790	
			LOW		710	
			QUIET		650	
	Type × Q'ty		Sirocco × 2			
	Motor output		W	50		
Sound pressure level *	Cooling	HIGH	dB (A)	38		
		MED		36		
		LOW		33		
		QUIET		31		
	Heating	HIGH		38		
		MED		36		
		LOW		33		
		QUIET		31		
Sound power level		Cooling	dB (A)	53		
		Heating		53		
Heat exchanger type	Dimensions (H × W × D)		mm	294 × 715 × 39.9		
	Fin pitch		mm	1.30		
	Rows × Stages		3 × 14			
	Pipe type		Copper			
	Fin type		Aluminum			
Enclosure	Material		Steel sheet			
	Color		White Approximate color of Munsell N9.25/			
Dimensions (H × W × D)	Net		mm	235 × 1,080 × 705		
	Gross			330 × 1,165 × 825		
Weight	Net		kg	24		
	Gross			33		
Connection pipe	Size	Liquid	mm (in)	Ø6.35 (Ø1/4)		
		Gas		Ø12.70 (Ø1/2)		
	Method		Flare			
Drain hose	Material		PVC			
	Tip diameter		mm	Ø25 (I.D.), Ø32 (O.D.)		
Operation range	Cooling			°C		
				%RH		
	Heating				°C	
Remote controller type			Wired remote controller, Wireless remote controller, Mobile app*3 (FGLair™)			
NOTES:						
<ul style="list-style-type: none"> • Specifications are based on the following conditions: <ul style="list-style-type: none"> – Cooling: Indoor temperature of 27 °CDB/19 °CWB, and outdoor temperature of 35 °CDB/24 °CWB. – Heating: Indoor temperature of 20 °CDB/15 °CWB, and outdoor temperature of 7 °CDB/6 °CWB. – Pipe length: 5 m, Height difference: 0 m. (Between outdoor unit and indoor unit.) • Protective function might work when using it outside the operation range. • *: Sound pressure level: <ul style="list-style-type: none"> – Measured values in manufacturer's anechoic chamber. – Because of the surrounding sound environment, the sound levels measured in actual installation conditions might be higher than the specified values here. 						

Floor type

Model name			AGYG09KVCA	AGYG12KVCA	AGYG14KVCA	
Power supply			230 V ~ 50 Hz			
Available voltage range			198—264 V			
Capacity	kW class		2.5	3.5	4.0	
Input power	W		16	20	23	
Running current	A		0.15	0.18	0.20	
Fan	Airflow rate	Cooling	HIGH	530	600	650
			MED	440	490	520
			LOW	360	380	400
			QUIET	270	270	270
	Heating	HIGH	530	600	650	
		MED	460	510	540	
		LOW	380	410	430	
		QUIET	270	270	270	
	Type × Q'ty		Cross flow fan × 2			
	Motor output		W			
		16 × 2				
Sound pressure level *	Cooling	dB (A)	HIGH	39	42	44
			MED	34	36	38
			LOW	28	30	31
			QUIET	22	22	22
	Heating	HIGH	39	42	44	
		MED	35	38	39	
		LOW	30	32	33	
		QUIET	22	22	22	
Sound power level	Cooling	dB (A)	52	55	56	
	Heating		52	55	56	
Heat exchanger type	Dimensions (H × W × D)		mm			
			378 × 550 × 26.6			
	Fin pitch		mm			
			1.2			
	Rows × Stages		2 × 18			
Pipe type		Copper tube				
Fin type		Aluminum				
Enclosure	Material		Polystyrene			
	Color		White			
Dimensions (H × W × D)	Net		mm			
			600 × 740 × 200			
Weight	Gross		mm			
			700 × 820 × 310			
Connection pipe	Net		kg			
			14			
Drain hose	Gross		kg			
			18			
	Size	Liquid	mm (in)			
		Gas	Ø6.35 (Ø1/4)			
	Method		Ø9.52 (Ø3/8)			
			Flare			
Operation range	Material		PP + LLDPE			
	Tip diameter		mm			
			Ø13.8 (I.D.), Ø15.8 to Ø16.7 (O.D.)			
Remote controller type	Cooling		°C			
			18 to 32			
	Heating		%RH			
			80 or less			
			°C			
			30 or less			
Remote controller type			Wireless (Wired, Simple mobile app [option])			

NOTES:

- Specifications are based on the following conditions:
 - Cooling: Indoor temperature of 27 °CDB/19 °CWB, and outdoor temperature of 35 °CDB/24 °CWB.
 - Heating: Indoor temperature of 20 °CDB/15 °CWB, and outdoor temperature of 7 °CDB/6 °CWB.
 - Pipe length: 5 m, Height difference: 0 m. (Between outdoor unit and indoor unit.)
- Protective function might work when using it outside the operation range.
- *: Sound pressure level:
 - Measured values in manufacturer's anechoic chamber.
 - Because of the surrounding sound environment, the sound levels measured in actual installation conditions might be higher than the specified values here.

1-2. Outdoor unit

Type				Inverter heat pump	
Model name				AOYG18KBTA3	
Power source				230 V 50 Hz	
Available voltage range				198—264V	
Standard combination of indoor unit				Wall mounted ASYG07KMCC ×3	
				Wall mounted ASYG09KMCC ×2	
Capacity	Cooling	Rated	kW	5.4	6.8
			Btu/h	18,400	23,200
		Min.—Max.	kW	1.8—7	1.8—8.5
			Btu/h	6,100—23,800	6,100—29,000
	Heating	Rated	kW	6.8	8.0
			Btu/h	23,200	27,300
		Min.—Max.	kW	2.0—8.0	2.0—9.2
			Btu/h	6,800—27,300	6,800—31,400
Input power	Cooling	Rated	kW	1.13	1.74
				Max.	1.90
	Heating	Rated		1.39	1.82
				Max.	1.85
Current	Cooling	Rated	A	5.1	7.7
	Heating	Rated		6.2	8.1
EER	Cooling			4.78	3.90
COP	Heating			4.89	4.40
Starting current			A	6.2	8.1
Maximum operating current *1			A	12.0	14.5
Fan	Type × Q'ty			Propeller × 1	
	Airflow rate	Cooling	m ³ /h	2,220	2,270
		Heating		2,160	2,730
	Motor output		W	49	49
Sound pressure level *2	Cooling			46	48
	Heating			49	53
Heat exchanger	Dimension (H × W × D)		mm	Main1: 672 × 881 × 18.19	
	Fin pitch			Main2: 672 × 851 × 18.19	
	Rows × Stages		1.3		
	Pipe type (Material)		Main1: 1 × 32		
	Fin type (Material)		Main2: 1 × 32		
Compressor	Type		DC twin rotary		
	Motor output		W	1,200	
Refrigerant	Type		R32 (675)		
	Charge		g	1,800	
Refrigerant oil	Type		RmM68AF		
	Amount		cm ³	550	
Enclosure	Material		Steel sheet		
	Color		Beige (Approximate color of Munsell 10YR 7.5/1.0 NN)		
Dimensions (H × W × D)	Net		mm	716 × 820 × 315	
	Gross			890 × 1,027 × 445	
Weight	Net		kg	46	
	Gross			55	
Connection pipe	Size	Liquid	mm (in)	Ø6.35 (Ø1/4) × 3	
		Gas		Ø9.52 (Ø3/8) × 3 Ø9.52 (Ø3/8) × 2, Ø12.70 (Ø1/2) × 1	
	Method		Flare		
	Pre-charge length (Total)		30		
	Maximum length (Total)		50		
	Maximum length (Each)		25		
	Minimum length (Total)		10		
	Minimum length (Each)		2.5		
	Maximum height difference between outdoor unit and each indoor units.		15		
	Maximum height difference between indoor units.		10		
Operation range	Cooling	°C	-10 to 46		
	Heating		-15 to 24		
Drain hose	Material		PP		
	Tip diameter		mm		
<p>NOTES:</p> <ul style="list-style-type: none"> Specifications are based on the following conditions: <ul style="list-style-type: none"> Power source of specifications: 230 V Pipe length: 5 m, Height difference: 0 m [Outdoor unit—Indoor unit] Cooling: Indoor temperature of 27.0 °CDB/19.0 °CWB, and outdoor temperature of 35 °CDB/24.0 °CWB. Heating: Indoor temperature of 20.0 °CDB/15.0 °CWB, and outdoor temperature of 7.0 °CDB/6.0 °CWB. *1: Maximum operating current is the total current of the indoor unit and the outdoor unit. *2: Sound pressure level <ul style="list-style-type: none"> Measured values in manufacturer's anechoic chamber. Because of the surrounding sound environment, the sound levels measured in actual installation conditions might be higher than the specified values here. For other combination, refer to the combination table. The protective function might work when using it outside the operation range. This data is based on EN 14511 standard. 					

Specifications for ErP Lot10				
Model name		AOYG18KBTA3		AOYG24KBTA3
Energy efficiency class	Cooling	A+++		
	Heating (Average)	A++		
Pdesign	Cooling	kW	5.4 (35 °C)	6.8 (35 °C)
	Heating (Average)		5.0 (-10 °C)	6.0 (-10 °C)
SEER	Cooling	kWh/kWh	8.60	8.50
SCOP	Heating (Average)		4.70	4.60
Annual energy consumption	QCE	kWh/a	220	280
	QHE (Average)		1,486	1,826
Sound power level	Cooling	HIGH	dB (A)	59
	Heating			61

2. Dimensions

2-1. Compact cassette type

■ Models: AUXG07KVLA, AUXG09KVLA, AUXG12KVLA, AUXG14KVLA, and AUXG18KVLA

Unit: mm

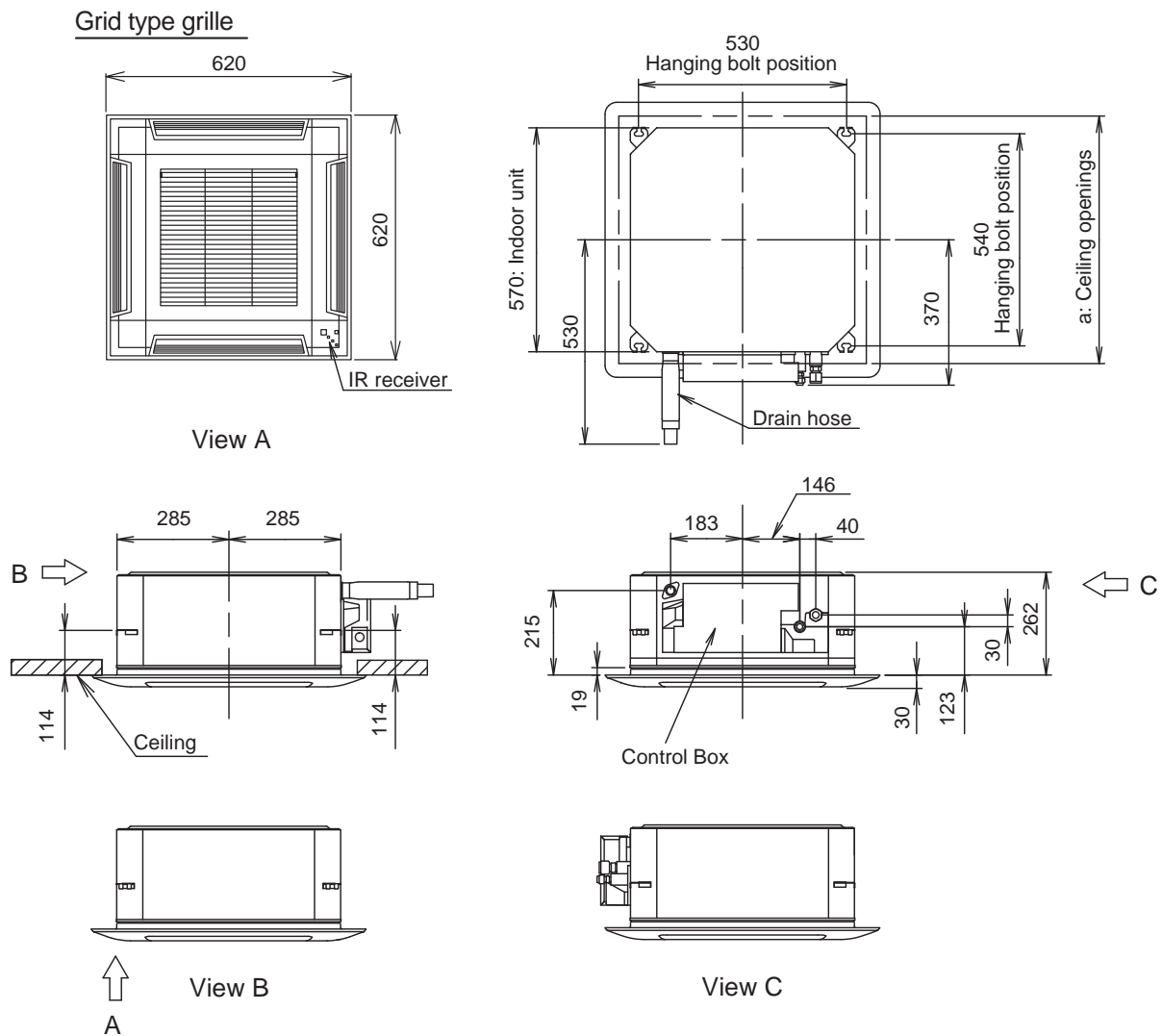

a: Ceiling openings		
Cassette grille (Option [Grid type])	mm	580 to 610

● Installation space requirement

Unit: mm

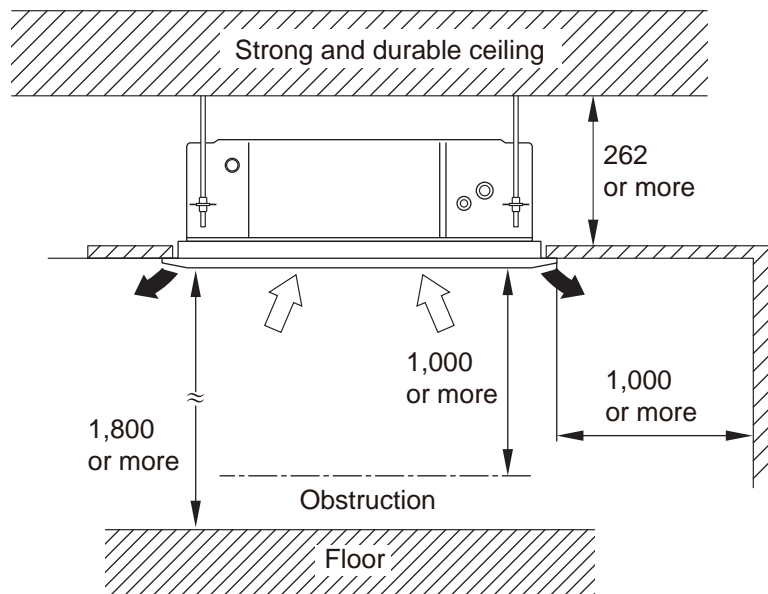

Maximum height from floor to ceiling (Unit: mm)		
	07 and 09 models	12 or larger models
Standard	2,700	
High ceiling	—	3,000

3-way direction setting:

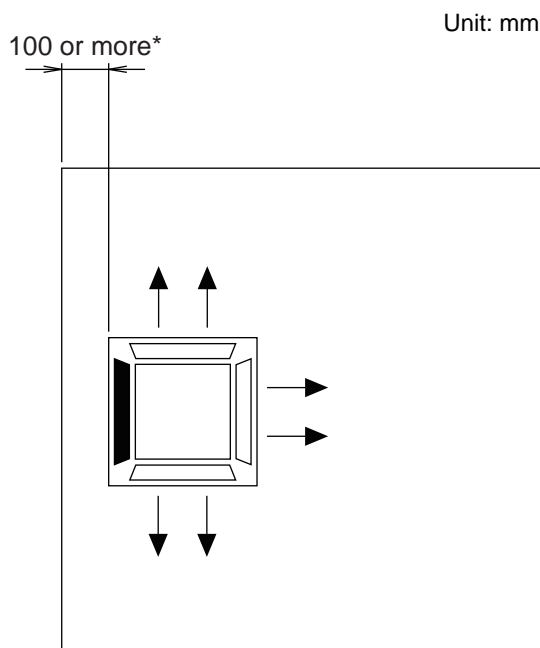

NOTES:

- To set "3-direction", optional Air outlet shutter plate (UTR-YDZB) must be installed, and the "outlet-direction" need to be switched to "3-way" by remote controller.
*When installing the indoor unit, be careful about the maintenance space.
- In 3-way outlet mode, changing of ceiling height setting by function setting 20 is prohibited.
(Ceiling height setting [function setting 20] is allowed to be changed only in 4-way outlet mode.)

2-2. Mini duct type

■ Models: ARXG07KSLAP, ARXG09KSLAP, ARXG12KSLAP, and ARXG14KSLAP

Unit: mm

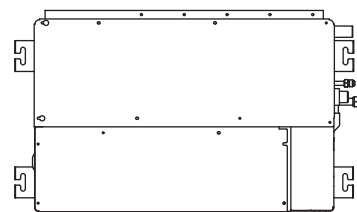
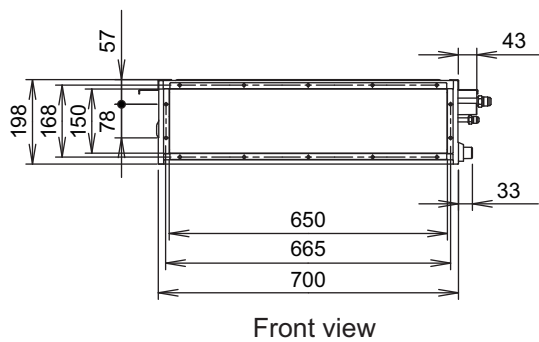
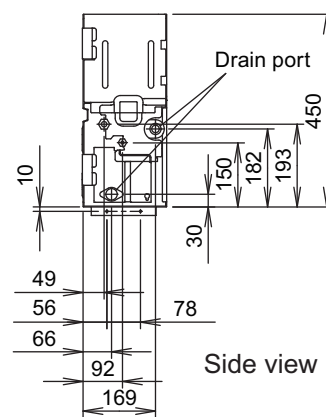
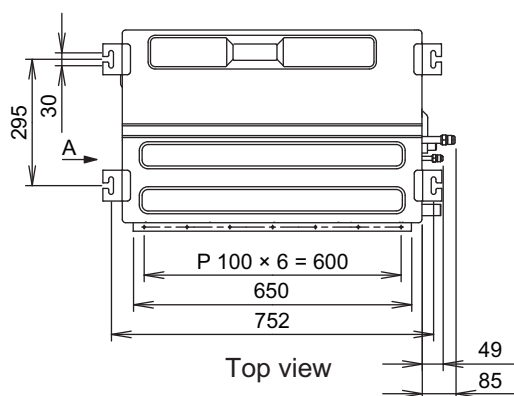
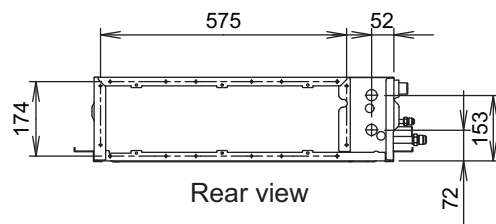

■ Model: ARXG18KSLAP

Unit: mm

GENERAL INFORMATION

GENERAL INFORMATION

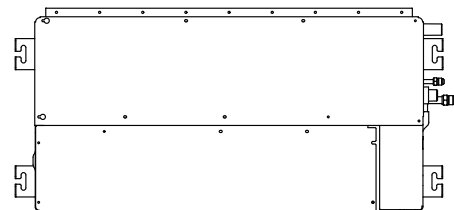
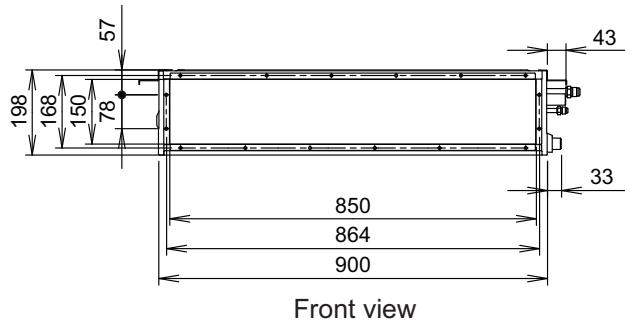
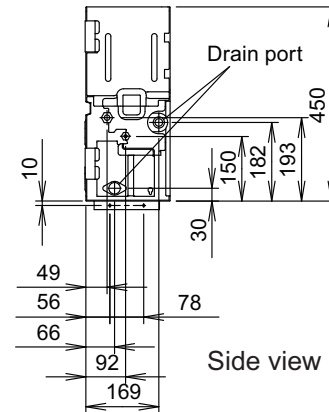
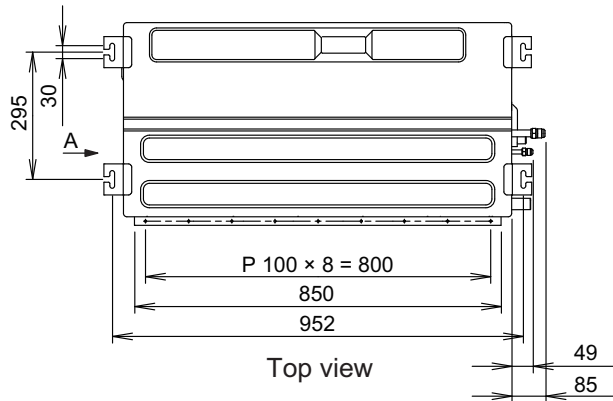
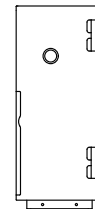
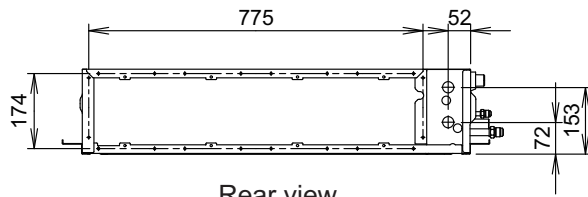

● Installation space requirement

Provide sufficient installation space for product safety.

Unit: mm

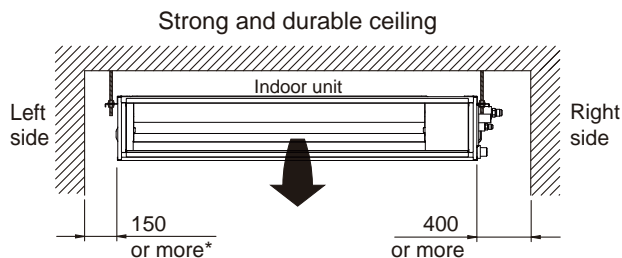

*: 400 or more when drain from drain pipe

- When intaking air from back:

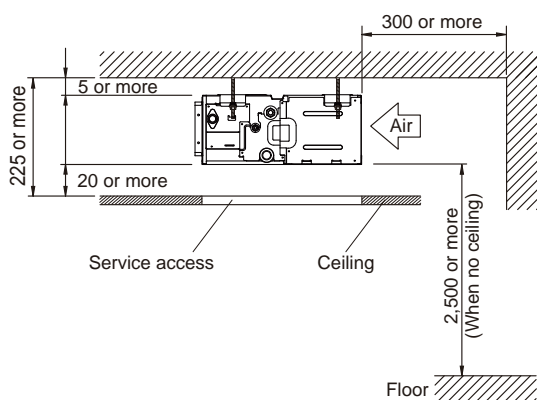

- When intaking air from bottom:

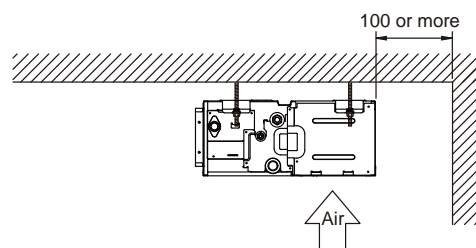

● Maintenance space requirement

For future maintenance and service access, provide sufficient maintenance space.

NOTE: Do not place any wiring or illumination in the maintenance space, as they will impede service.

Unit: mm

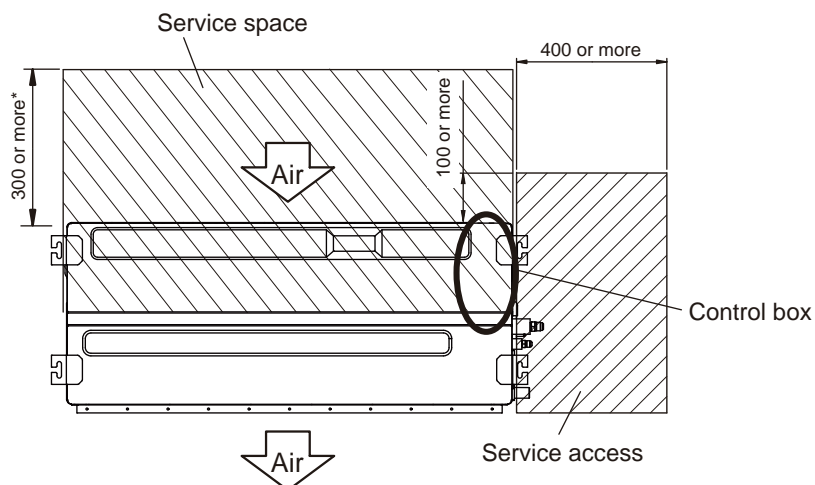

*: More than 100 when intaking air from bottom

Top view

2-3. Slim duct type

■ Models: ARXG07KLLAP, ARXG09KLLAP, ARXG12KLLAP, and ARXG14KLLAP

Unit: mm

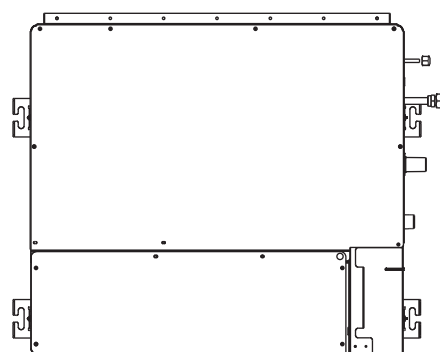
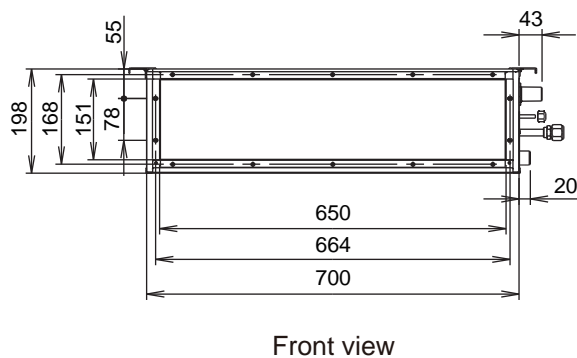
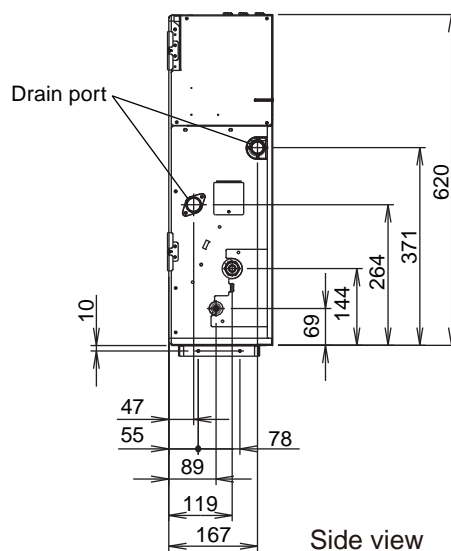
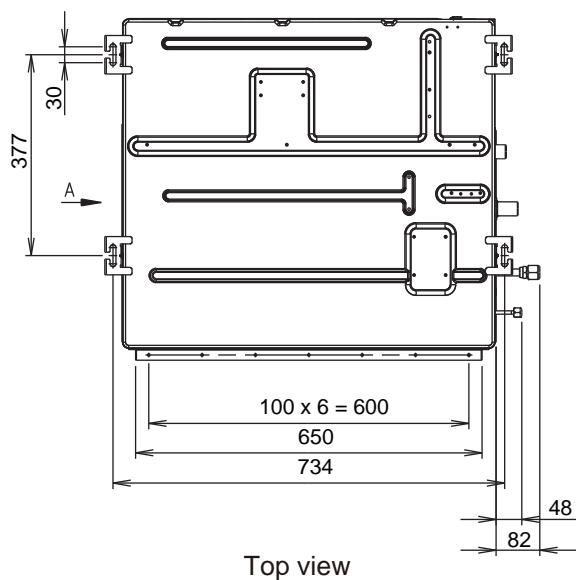
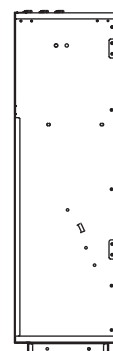
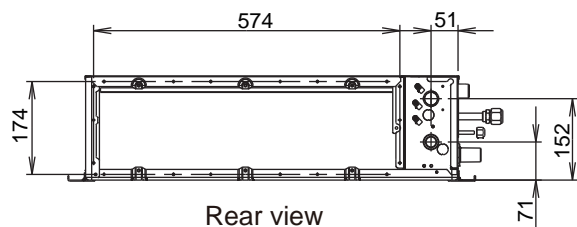

■ Model: ARXG18KLLAP

Unit: mm

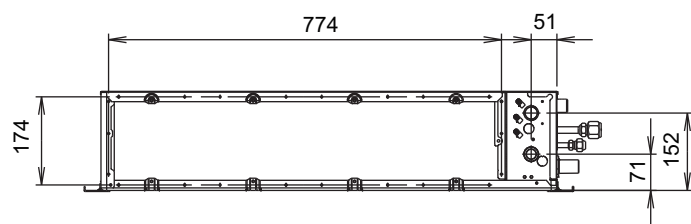

Rear view

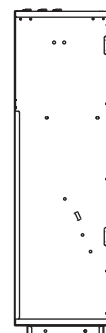

View A

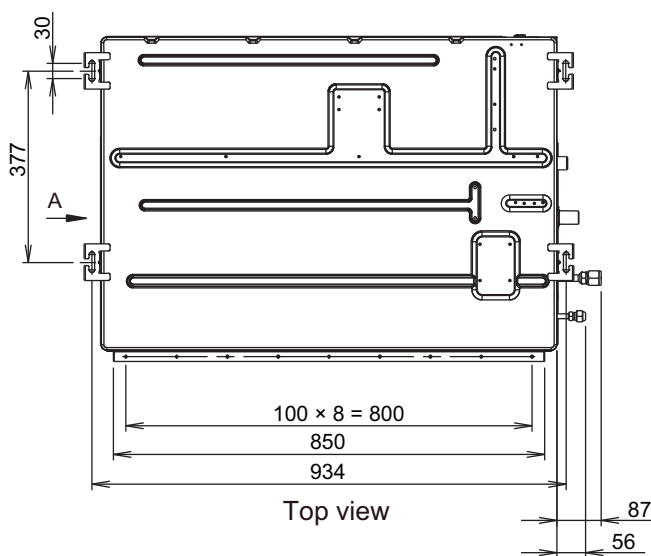

Top view

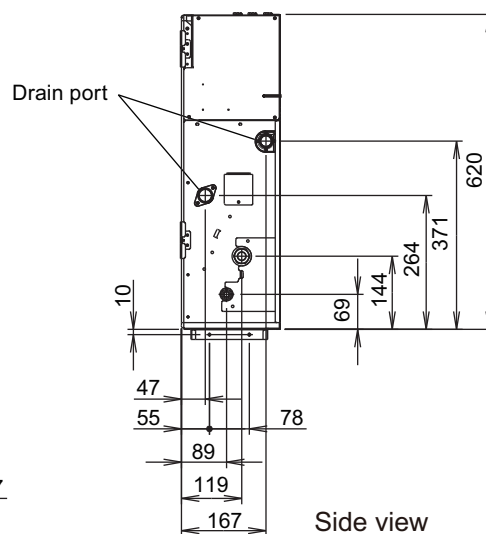

Side view

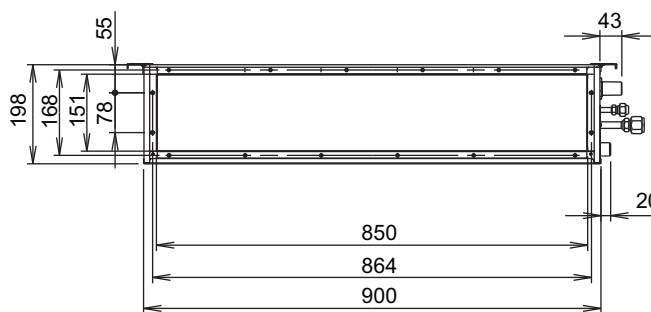

Front view

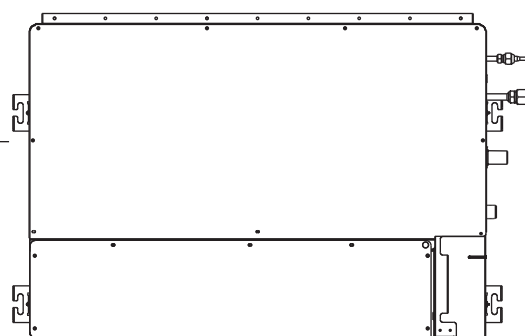

Bottom view

● Installation space requirement

Provide sufficient installation space for product safety.

In ceiling-concealed installations:

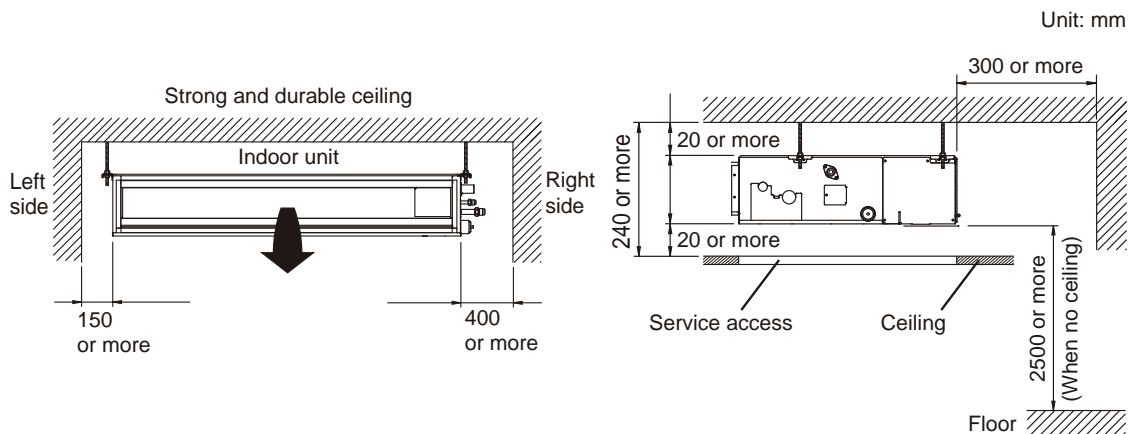

● Maintenance space requirement

For future maintenance and service access, provide sufficient maintenance space.

NOTE: Do not place any wiring or illumination in the maintenance space, as they will impede service.

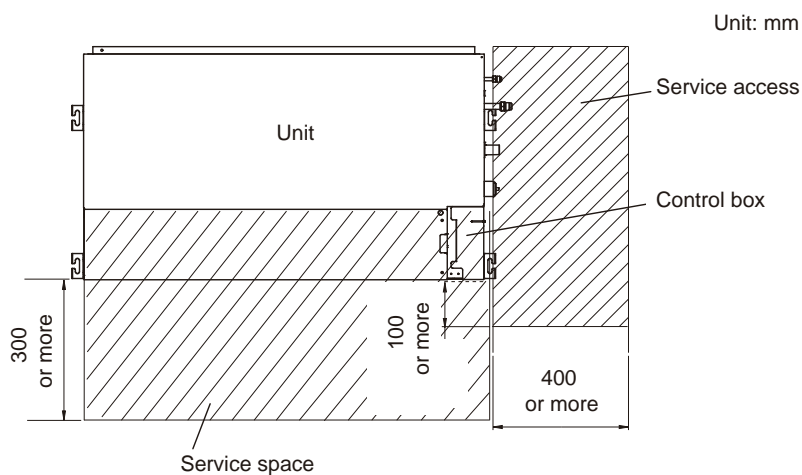

2-4. Wall mounted type

■ Models: ASYG07KGTB, ASYG09KGTB, ASYG12KGTB, and ASYG14KGTB

Unit: mm

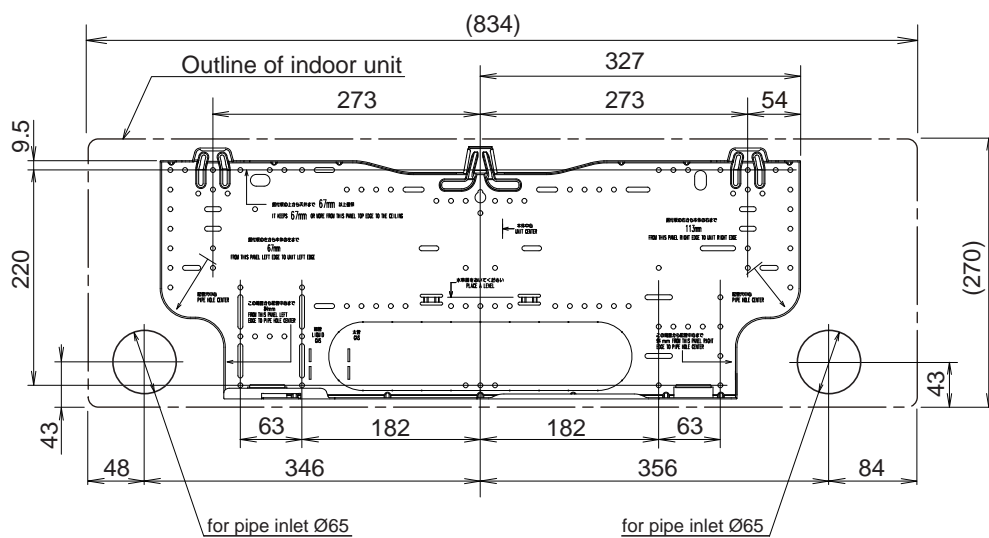
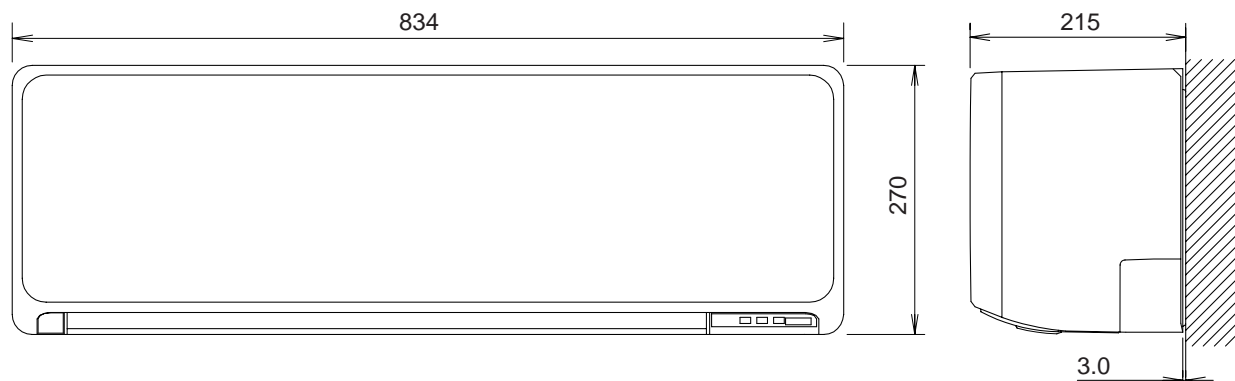

● Installation space requirement

Provide sufficient installation space for product safety.

Unit: mm

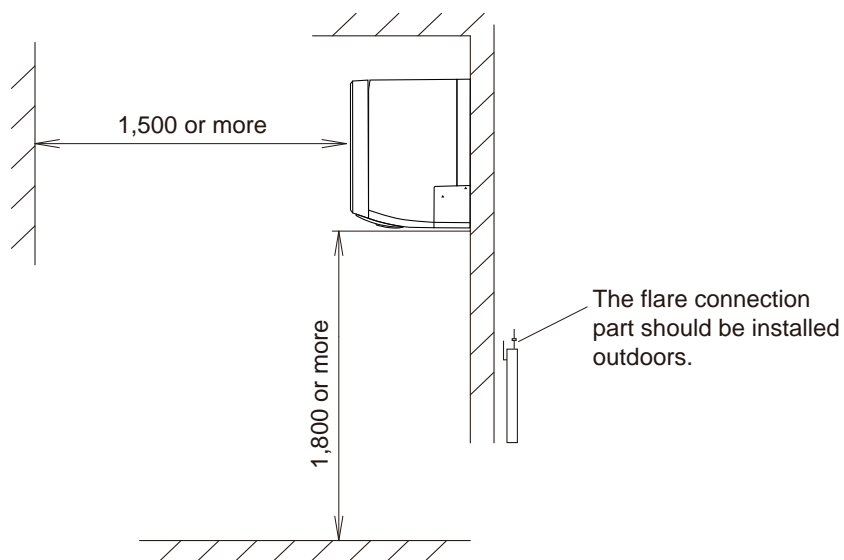
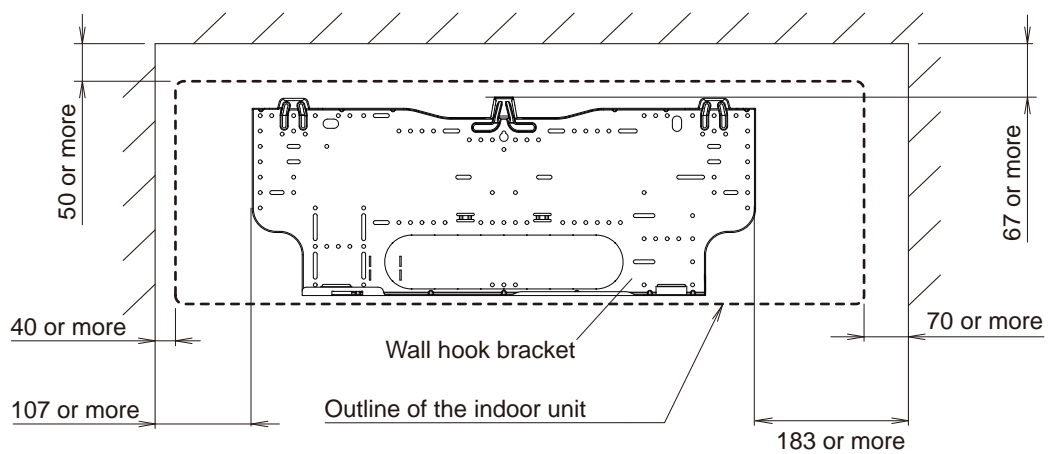

■ Model: ASYG18KMTB

Unit: mm

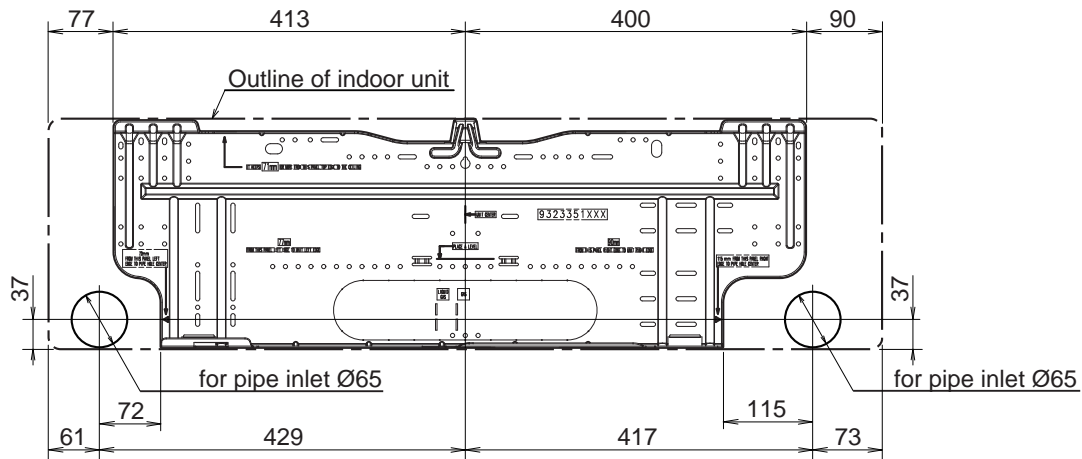
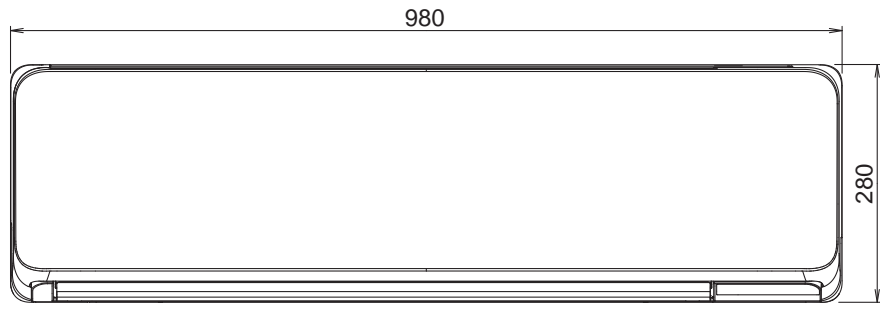

● Installation space requirement

Provide sufficient installation space for product safety.

Unit: mm

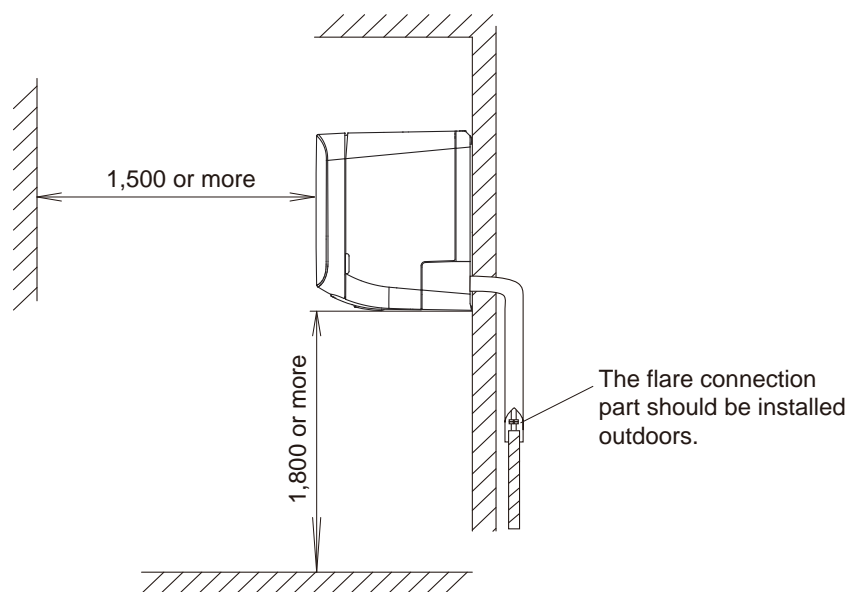
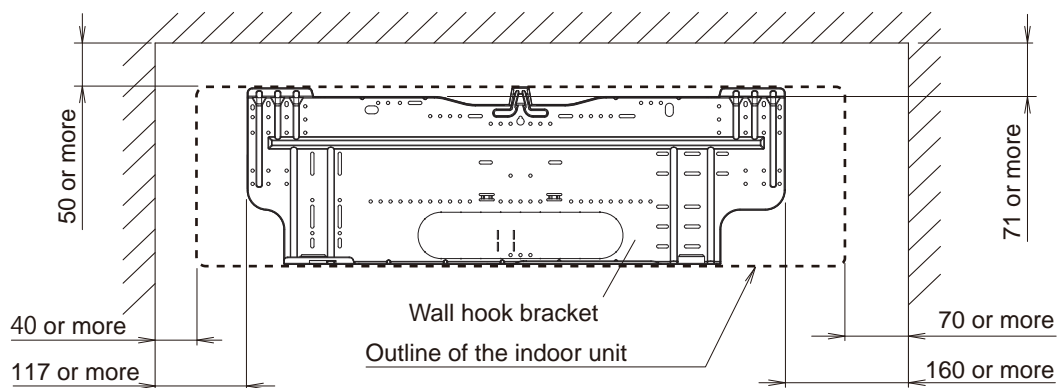

■ Models: ASYG07KMCC, ASYG09KMCC, ASYG12KMCC, and ASYG14KMCC

Unit: mm

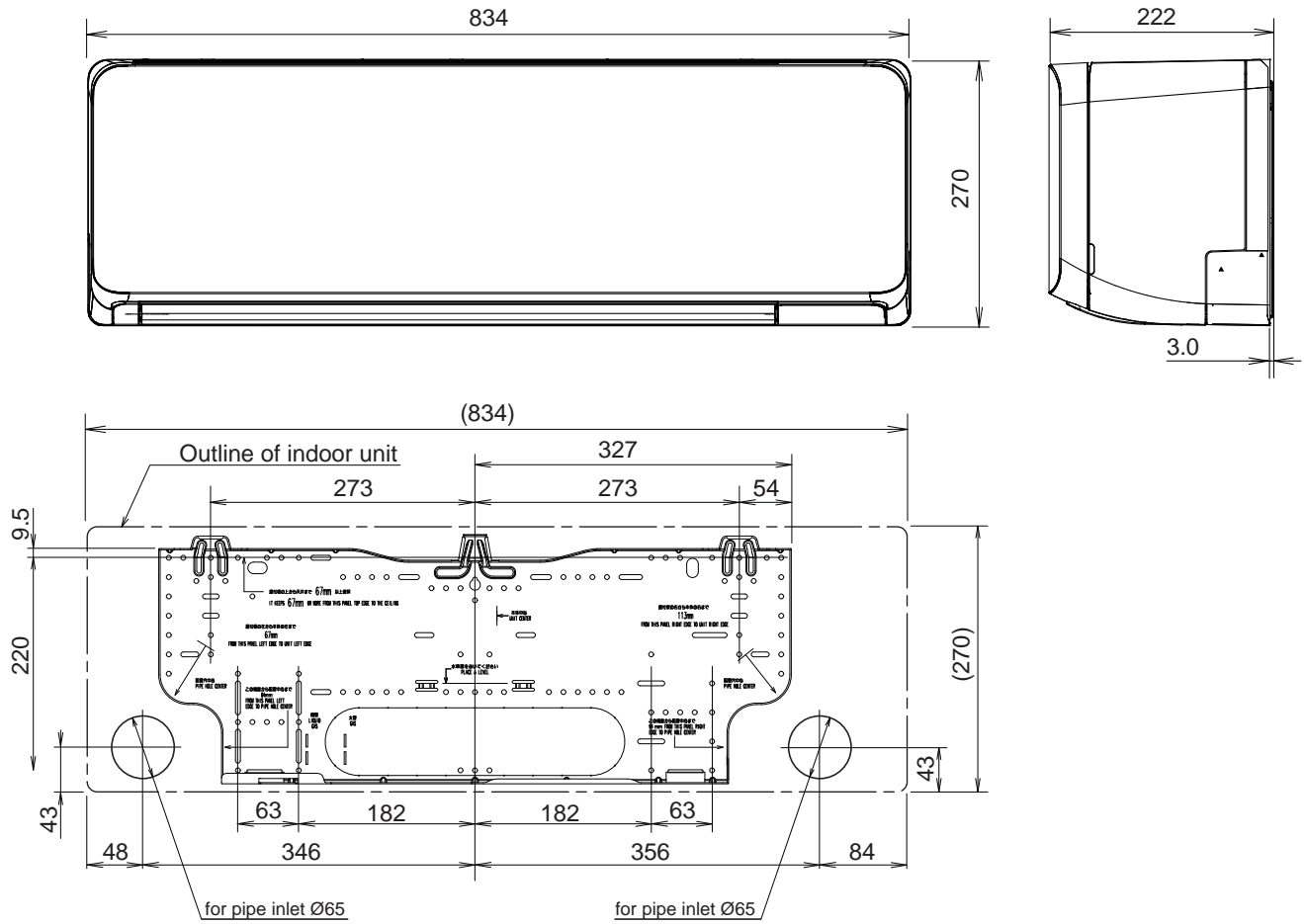

● Installation space requirement

Provide sufficient installation space for product safety.

Unit: mm

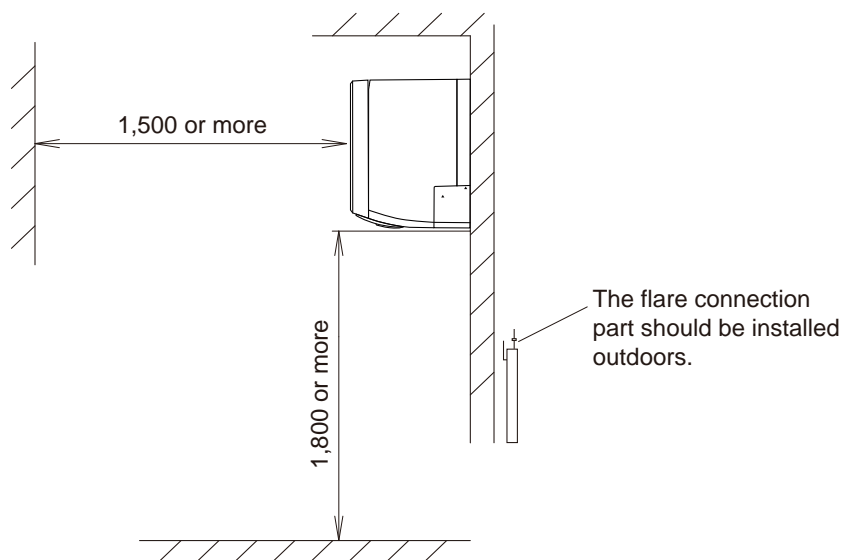
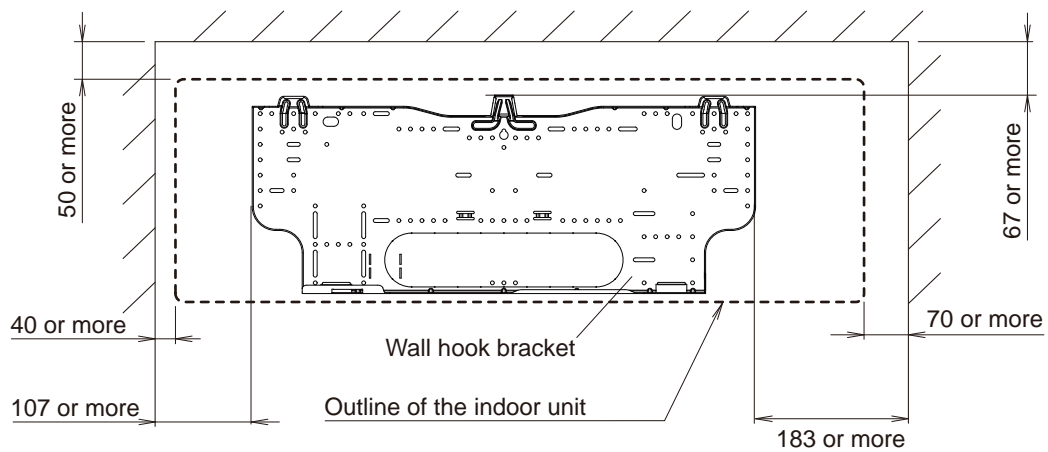

■ Models: ASYG07KETA, ASYG09KETA, ASYG12KETA, ASYG14KETA, ASYG07KETA-B, ASYG09KETA-B, ASYG12KETA-B, and ASYG14KETA-B

Unit: mm

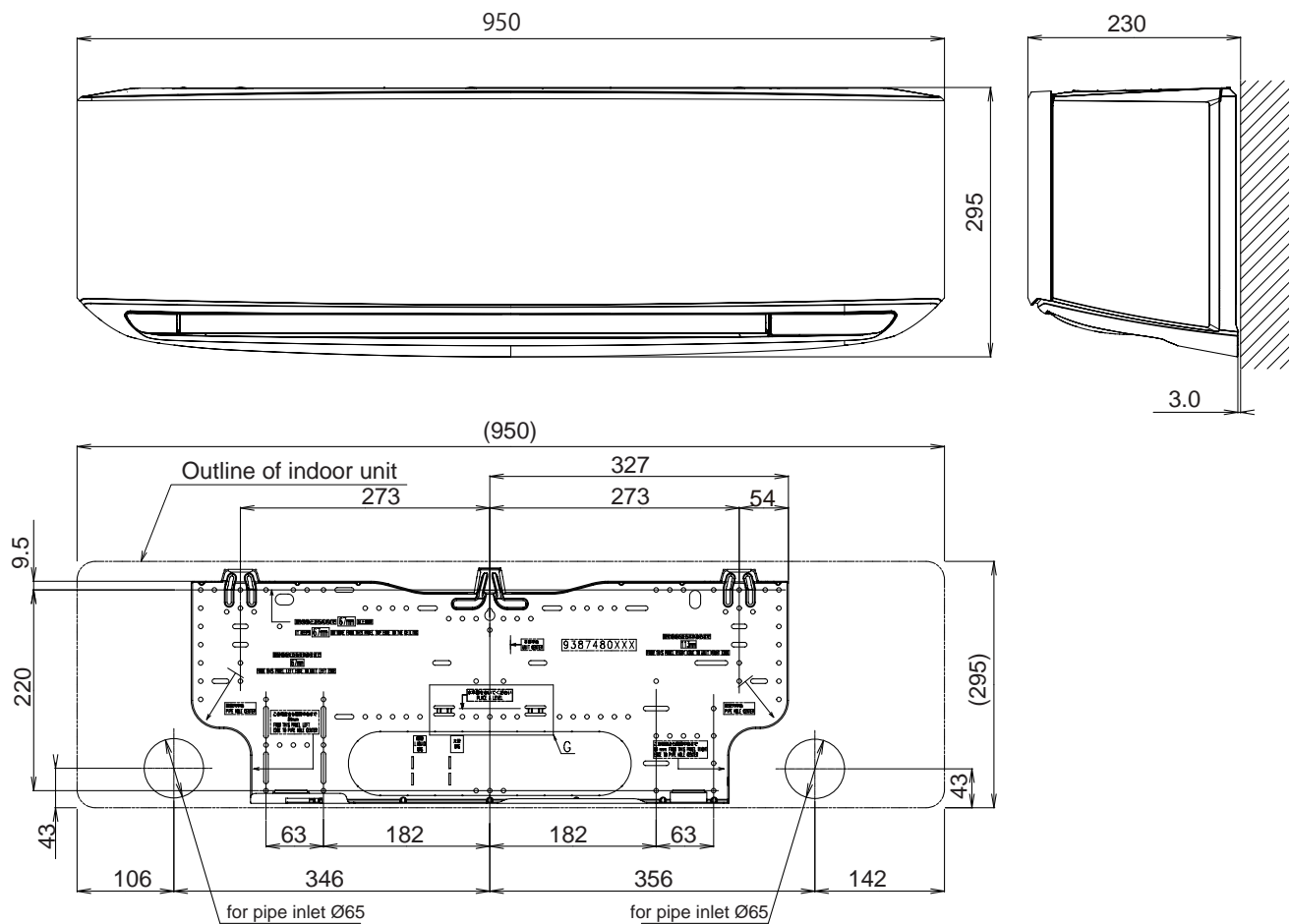

● Installation space requirement

Provide sufficient installation space for product safety.

Unit: mm

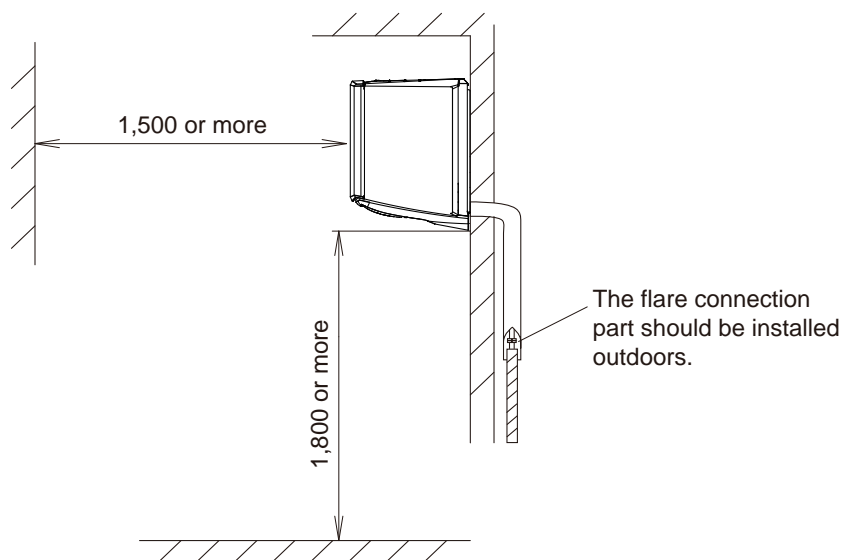
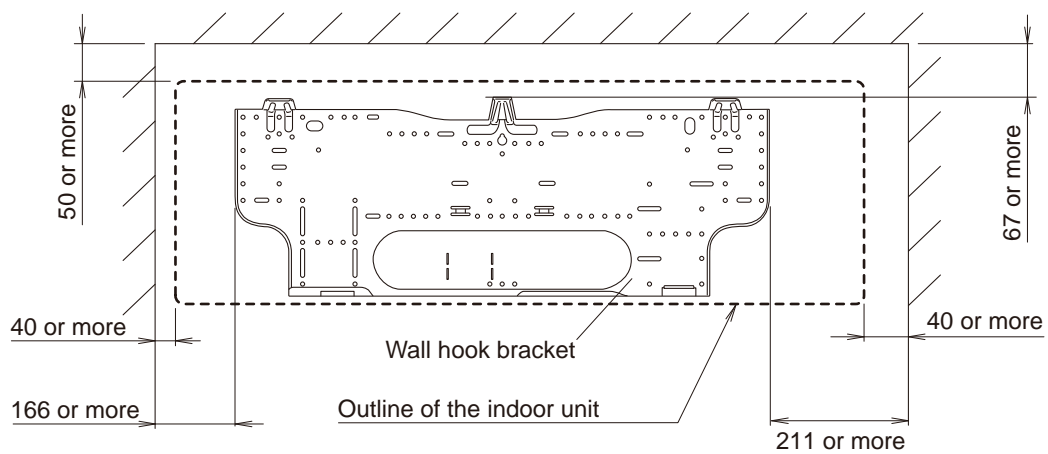

2-5. Ceiling type

■ Model: ABYG18KRTA

Unit: mm

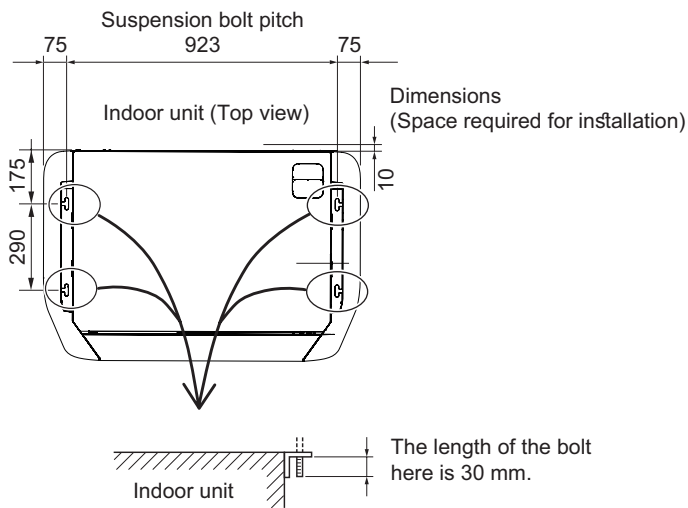
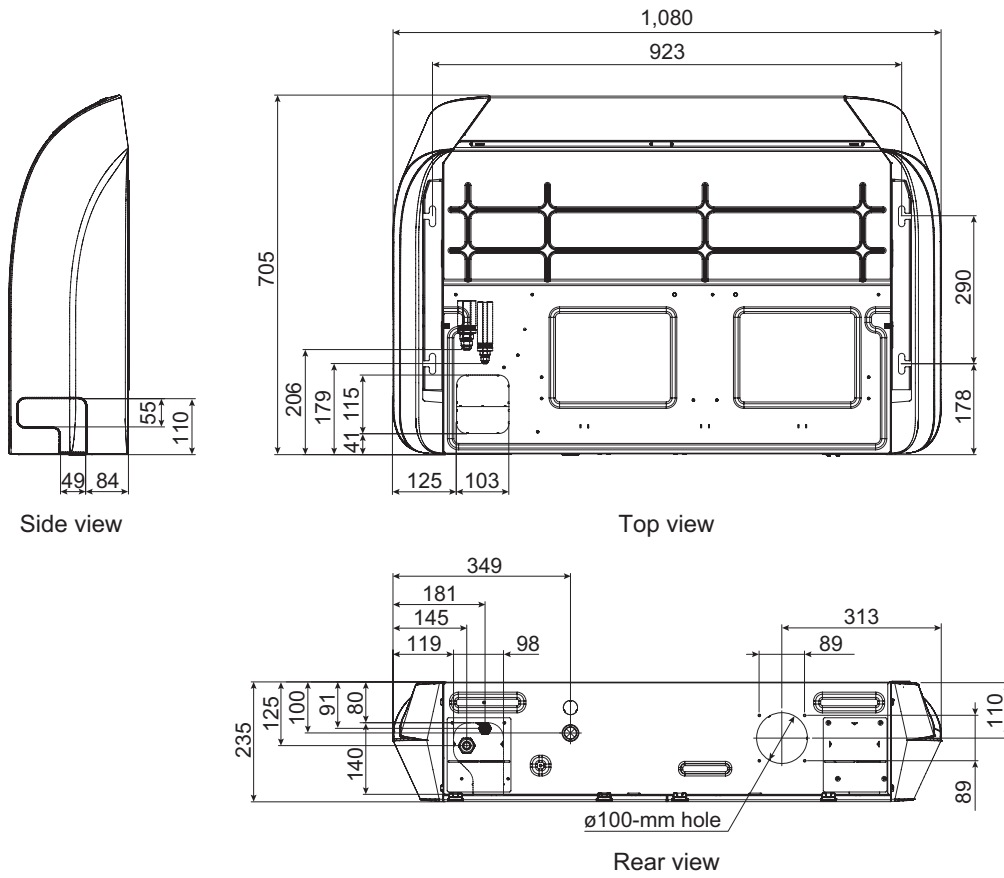

■ Installation space requirement

Unit: mm

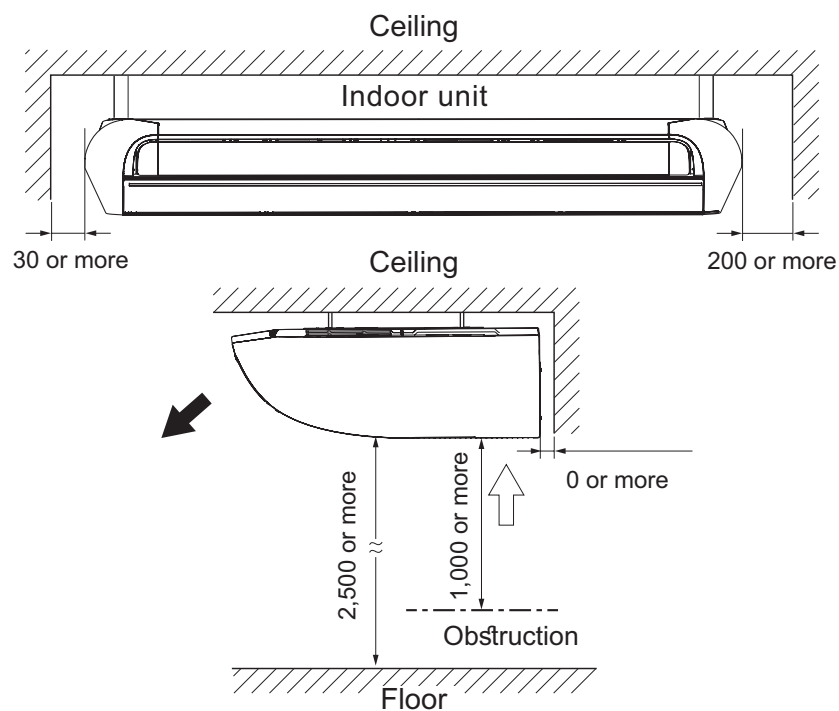

Required ceiling height varies according to the ceiling mode setting of function setting No. 20.

Ceiling height (m)		
Ceiling mode	Standard	High ceiling
18 model	2.7	3.5

2-6. Floor type

■ Models: AGYG09KVCA, AGYG12KVCA, and AGYG14KVCA

Unit: mm

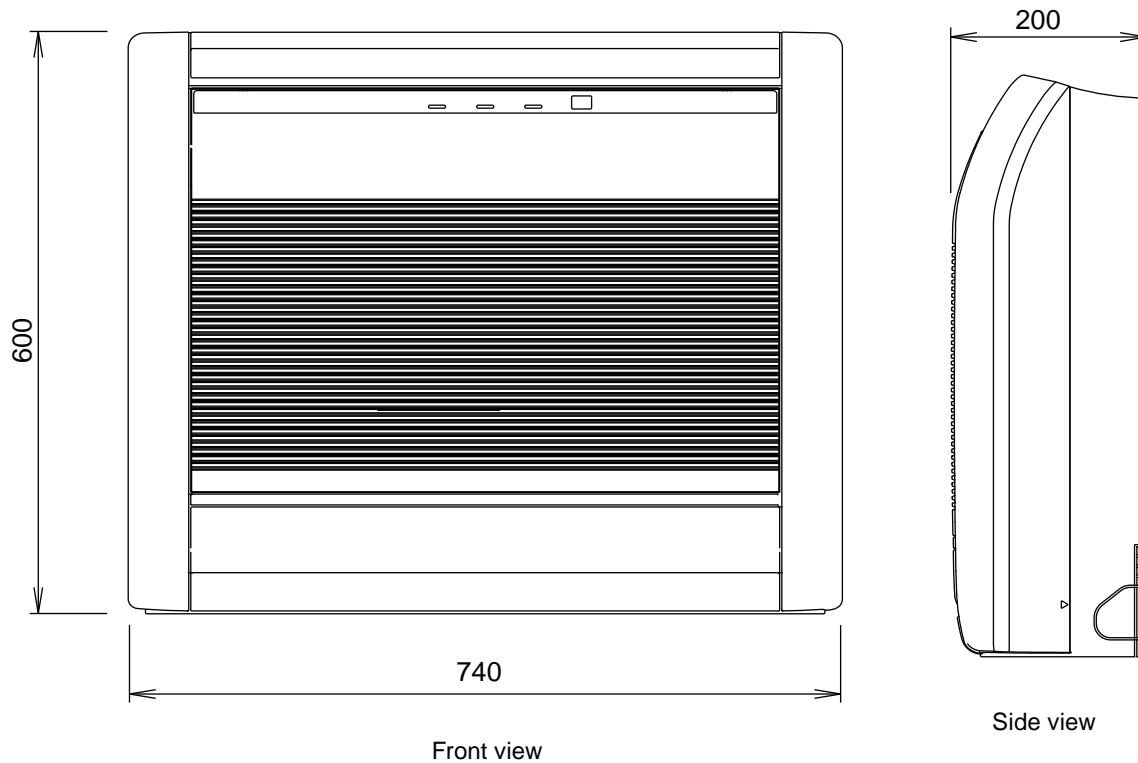

● Installation space

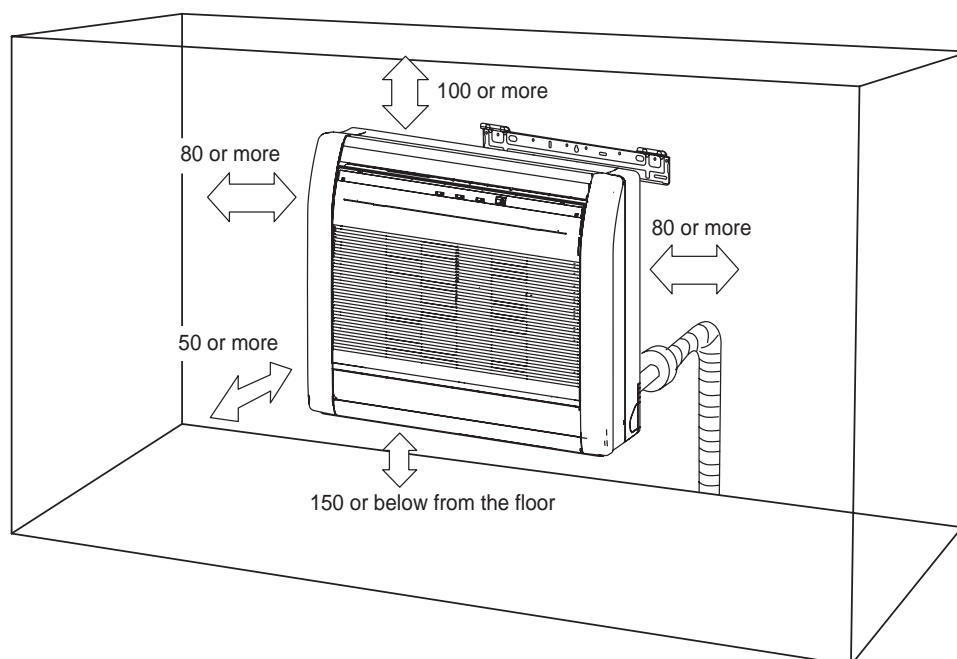

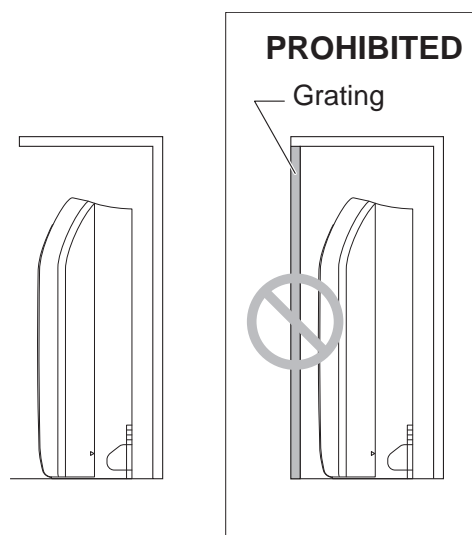

⚠ WARNING

- The appliance shall be installed, operated and stored in a room with a floor area larger than X m².

Amount of refrigerant charge M (kg)	Minimum room area X (m ²)
$M \leq 1.22$	-
$1.22 < M \leq 1.23$	12.99
$1.23 < M \leq 1.50$	19.31
$1.50 < M \leq 1.75$	26.28
$1.75 < M \leq 2.0$	34.33
$2.0 < M \leq 2.5$	53.63
$2.5 < M \leq 3.0$	77.23
$3.0 < M \leq 3.5$	105.12
$3.5 < M \leq 4.0$	137.29

(IEC 60335-2-40)

2-7. Outdoor unit

■ Models: AOYG18KBTA3 and AOYG24KBTA3

Unit: mm

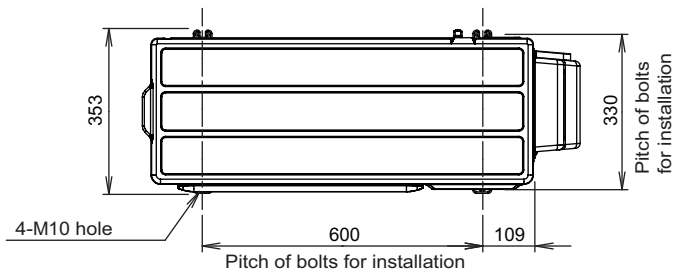

Top view

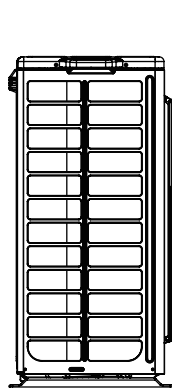

Side view

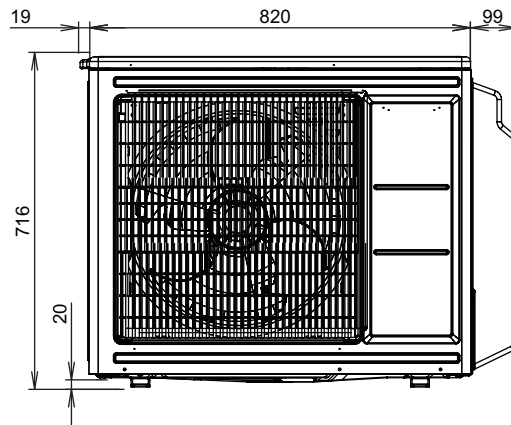

Front view

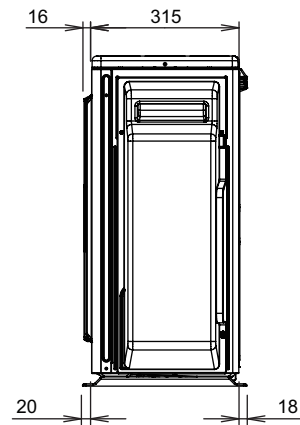

Side view

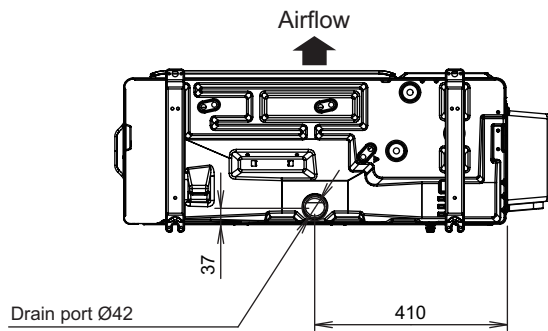

Bottom view

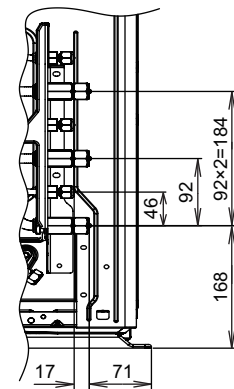

Side view (Valve part)

2. TECHNICAL DATA AND PARTS LIST

CONTENTS

2. TECHNICAL DATA AND PARTS LIST

1. Precautions	02-1
2. Cassette grille (optional part) parts list	02-2
2-1. Model: UTG-UFYF-W	02-2
3. Indoor unit parts list	02-5
3-1. Compact cassette type	02-5
3-2. Mini duct type	02-10
3-3. Slim duct type	02-17
3-4. Wall mounted type.....	02-23
3-5. Ceiling type.....	02-50
3-6. Floor type	02-52
4. Outdoor unit parts list	02-58
4-1. Models: AOYG18KBTA3 and AOYG24KBTA3.....	02-58
5. Accessories	02-62
5-1. Compact cassette type	02-62
5-2. Mini duct type	02-63
5-3. Slim duct type	02-65
5-4. Wall mounted type.....	02-66
5-5. Ceiling type.....	02-69
5-6. Floor type	02-70
5-7. Outdoor unit.....	02-71
6. Refrigerant system diagrams	02-72
6-1. Models: AOYG18KBTA3 and AOYG24KBTA3.....	02-72
7. Wiring diagrams	02-73
7-1. Compact cassette type	02-73
7-2. Mini duct type and Slim duct type	02-74
7-3. Wall mounted type.....	02-75
7-4. Ceiling type.....	02-79
7-5. Floor type	02-80
7-6. Outdoor unit.....	02-81

1. Precautions

When you start servicing, pay attention to the following points. For detailed precautions, refer to the installation manual of the products.

⚠ CAUTION

- Service personnel
 - Any person who is involved with working on or breaking into a refrigerant circuit should hold a current valid certificate from an industry-accredited assessment authority, which authorizes their competence to handle refrigerants safely in accordance with an industry recognized assessment specification.
 - Servicing shall only be performed as recommended by the equipment manufacturer. Maintenance and repair requiring the assistance of other skilled personnel shall be carried out under the supervision of the person competent in the use of flammable refrigerants.
 - Servicing shall be performed only as recommended by the manufacturer.
 - Work
 - Prior to beginning work on systems containing flammable refrigerants, safety checks are necessary to ensure that the risk of ignition is minimized. When repairing the refrigerant system, refer to the precautions written in the installation manual of the products before you start servicing.
 - Work shall be undertaken under a controlled procedure so as to minimize the risk of a flammable gas or vapor being present while the work is being performed.
 - All maintenance staff and others working in the local area shall be instructed on the nature of work being carried out.
 - Work in confined spaces shall be avoided.
 - The area around the workspace shall be sectioned off.
 - Ensure that the conditions within the area have been made safe by control of flammable material.
 - Electric shock may occur. After turning off the power, always wait 5 minutes before touching electrical components.
 - Do not touch the fins of the heat exchanger. Touching the heat exchanger fins could result in damage to the fins or personal injury such as skin rupture.
 - Do not place any other electrical products or household belongings under the product.
 - Condensation dripping from the product might get them wet, and may cause damage or malfunction to the property.
 - Checking for presence of refrigerant
 - The area shall be checked with an appropriate refrigerant detector prior to and during work, to ensure the technician is aware of potentially flammable atmospheres.
 - Ensure that the leak detection equipment being used is suitable for use with flammable refrigerants, i.e. non-sparking, adequately sealed or intrinsically safe.
-
- Service parts information and design are subject to change without notice for product improvement.
 - For the latest information of the service parts, refer to our Service Portal.
<https://fujitsu-general.force.com/portal/>
 - Precise figure of the service parts listed in this manual may differ from the actual service parts.

2. Cassette grille (optional part) parts list

2-1. Model: UTG-UFYF-W

■ Panels

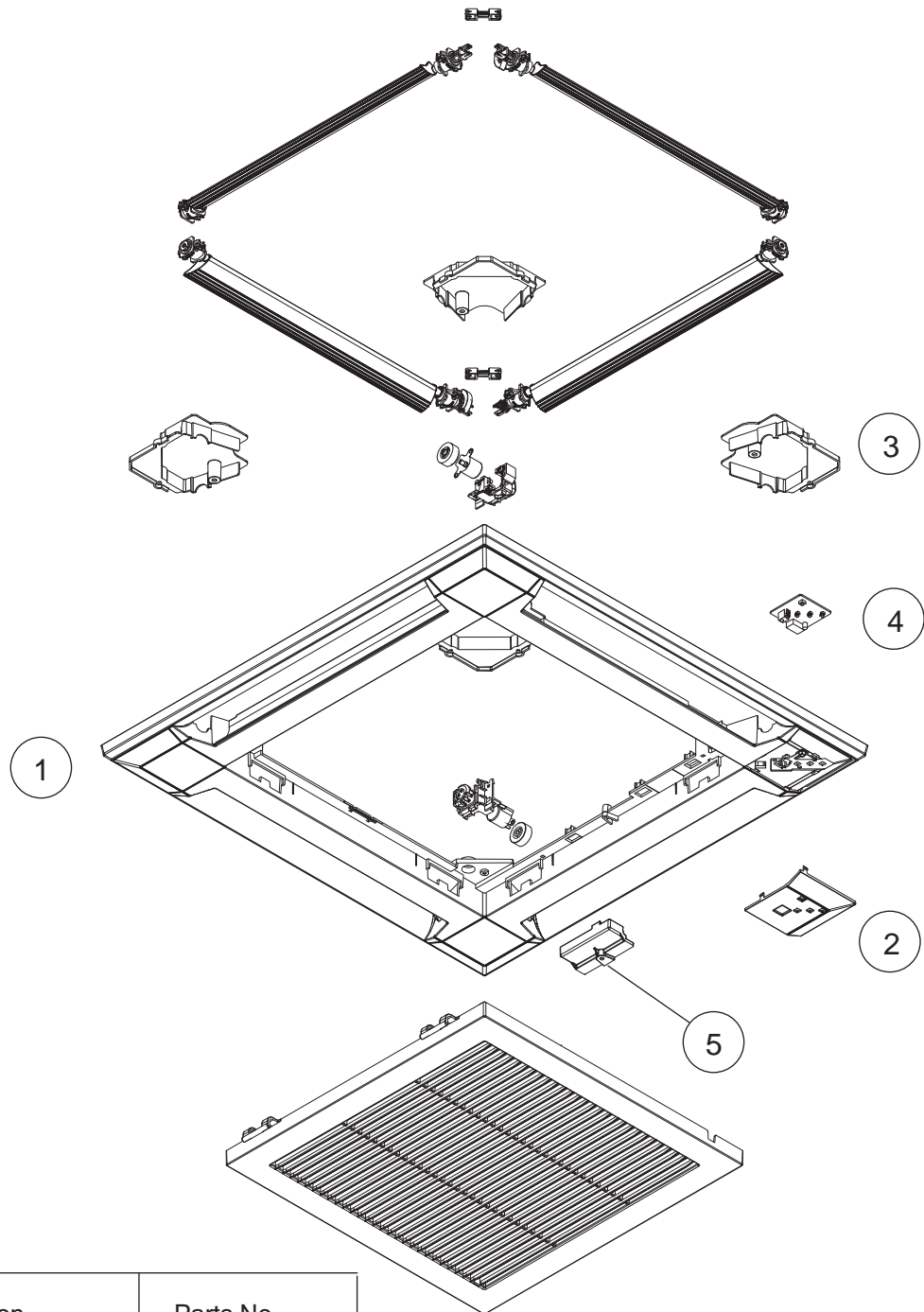

Ref	Description	Parts No.
1	Decoration Panel without Insulations	9382821005
2	Display panel assy	9383100031
3	Panel Cover without Insulations	9375530013
4	Indicator PCB	9711310002
5	Connector Cover	9375549015

Intake grille

TECHNICAL DATA
AND PARTS LIST

TECHNICAL DATA
AND PARTS LIST

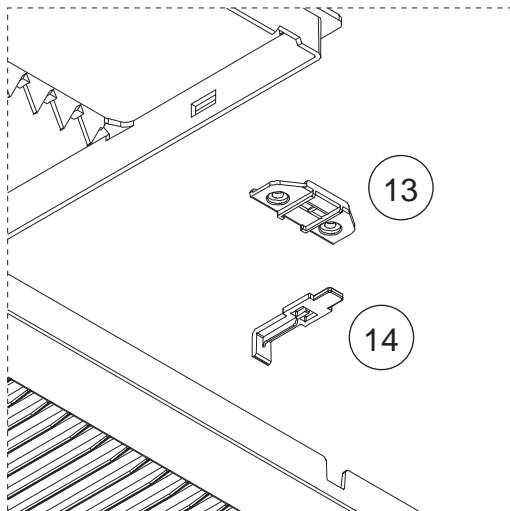
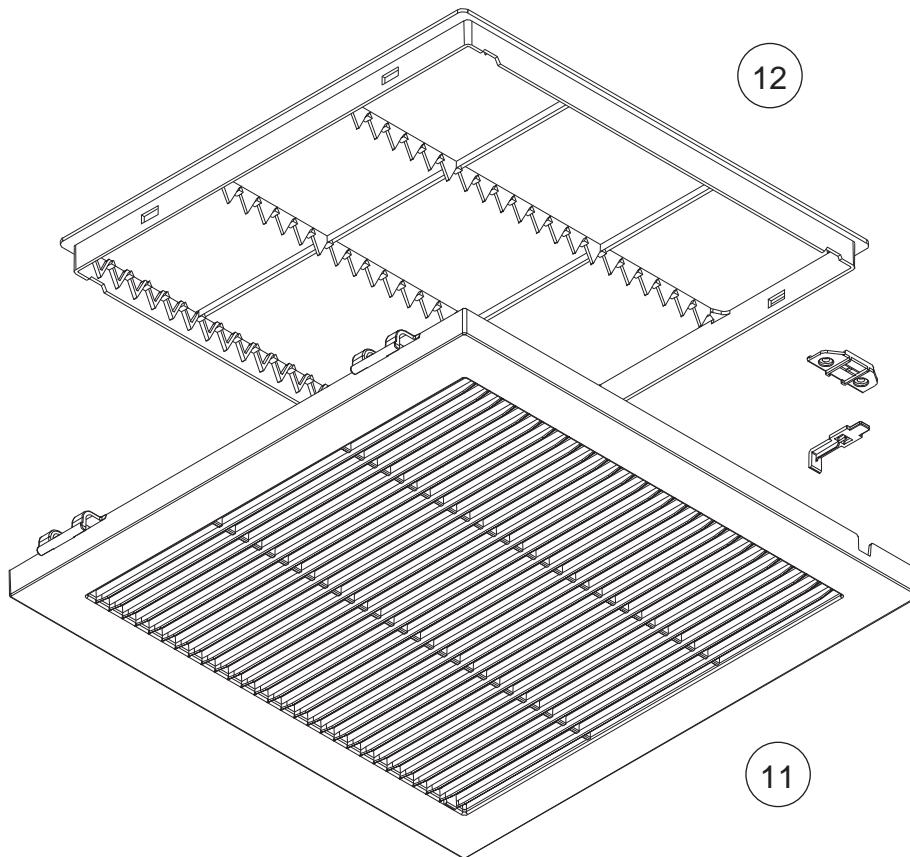

Ref	Description	Parts No.
11	Intake grille	9382863005
12	Long Life Filter	9375533014
13	Hook bracket	9375546014
14	Grille hook	9375532031

■ Louvers and motors

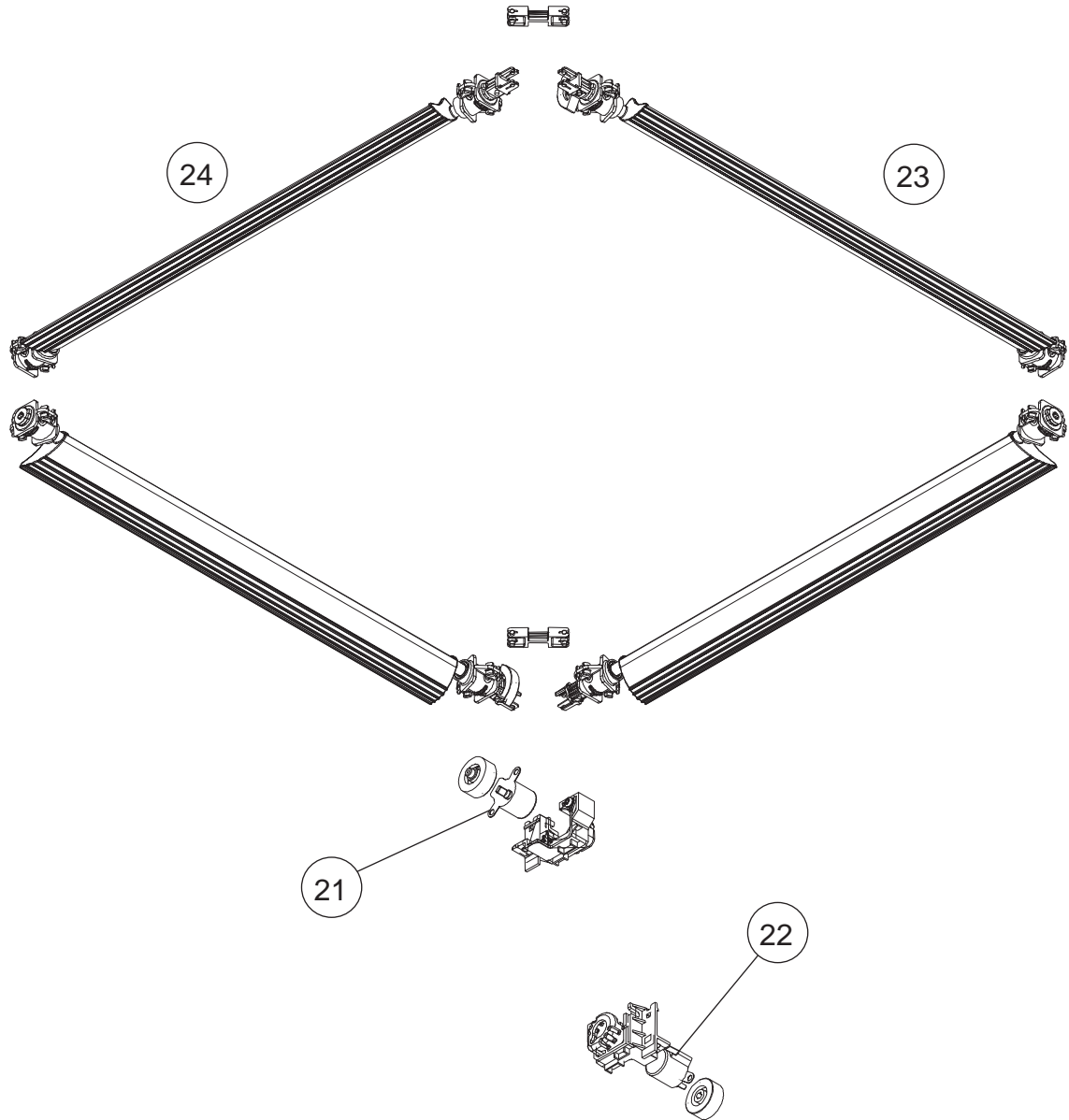

Ref	Description	Parts No.
21	Step Motor (White connector)	9900139070
22	Step Motor (Red connector)	9900139087
23	Flap assy A	9375727048
24	Flap assy B	9377759047

3. Indoor unit parts list

3-1. Compact cassette type

- Models: AUXG07KVLA, AUXG09KVLA, AUXG12KVLA, AUXG14KVLA, and AUXG18KVLA

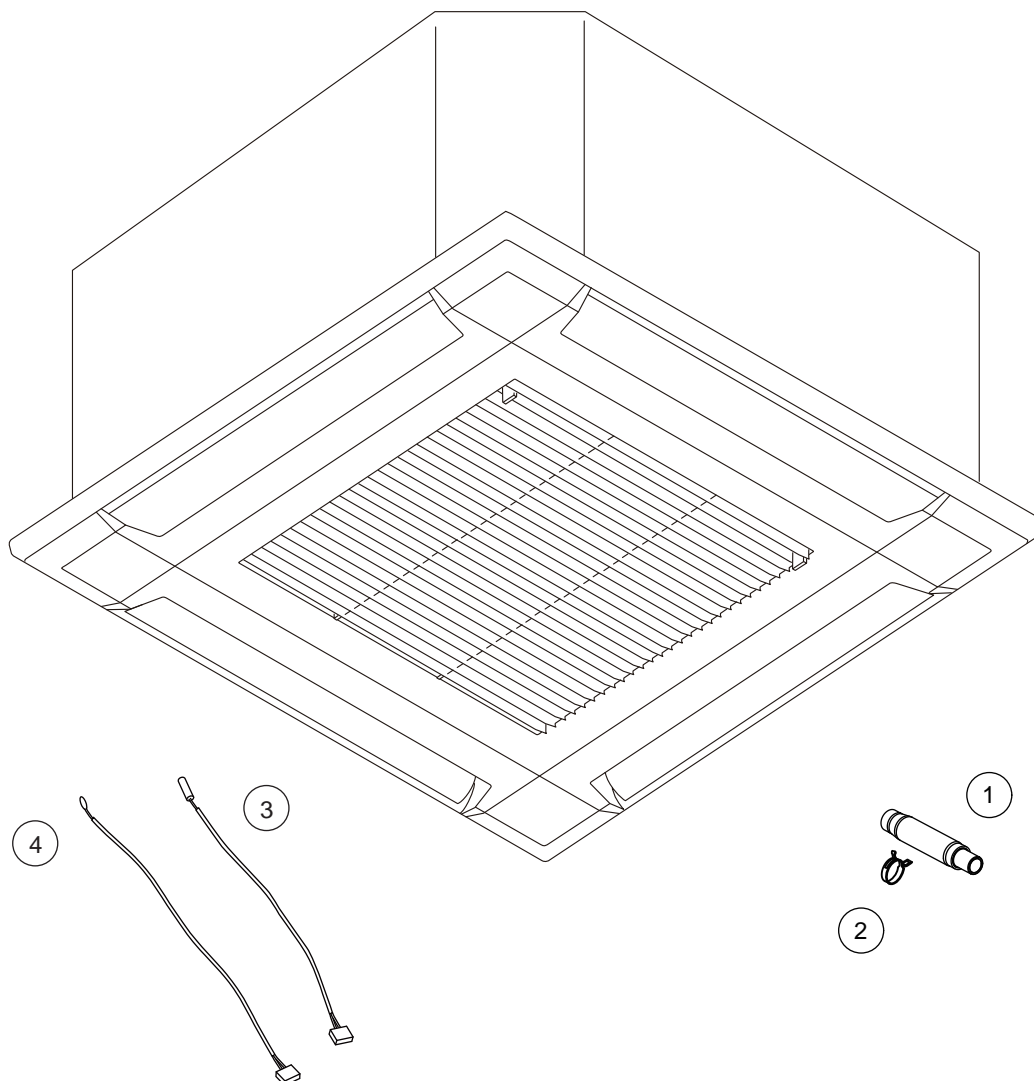

Item no.	Part no.	Part name	Service part
1	9379665001	Drain hose	◆
2	9379757010	Hose band	◆
3	9900942038	Pipe thermistor	◆
4	9900826000	Room thermistor	◆

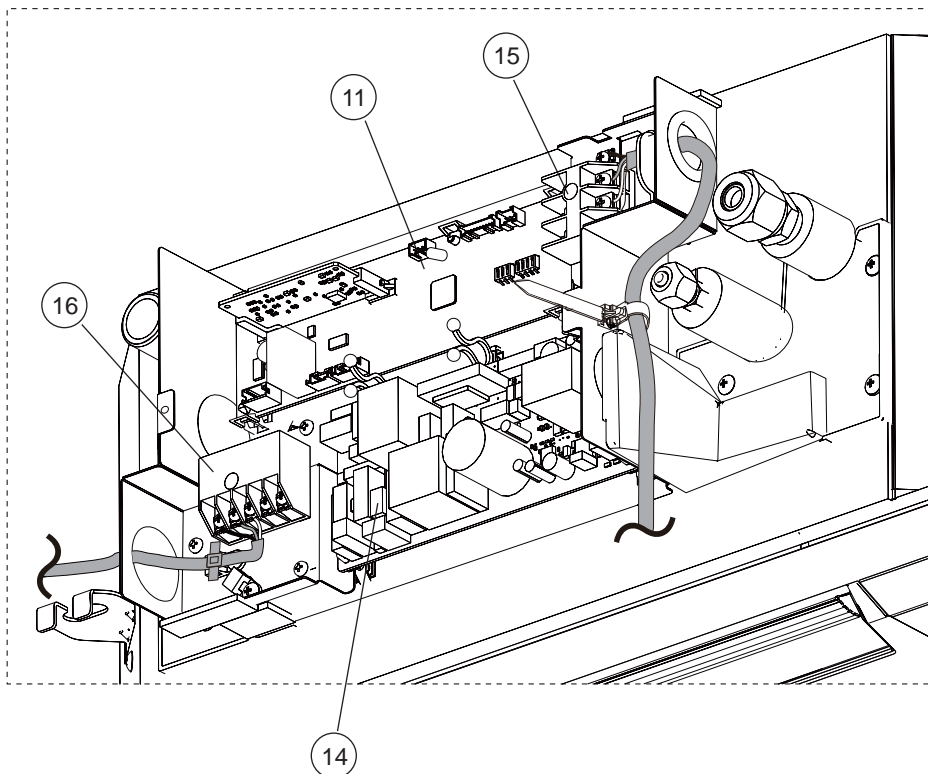
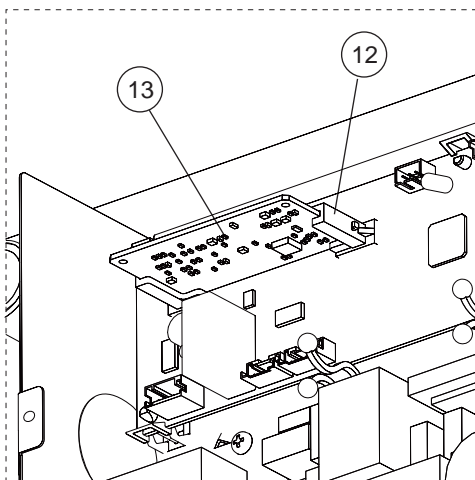

Item no.	Part no.	Part name	Service part
11	9710995965	Main PCB (For 07 model)	◆
	9710995743	Main PCB (For 09 model)	◆
	9710995750	Main PCB (For 12 model)	◆
	9710995705	Main PCB (For 14 model)	◆
	9710995767	Main PCB (For 18 model)	◆
12	0600063023	Holder	◆
13	9710019005	Communication PCB	◆
14	9710661006	Power supply PCB	◆
15	9900568009	Terminal	◆
16	9900896003	Terminal	◆

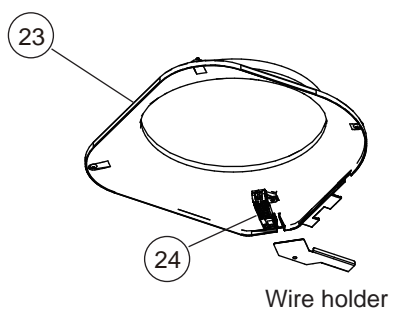
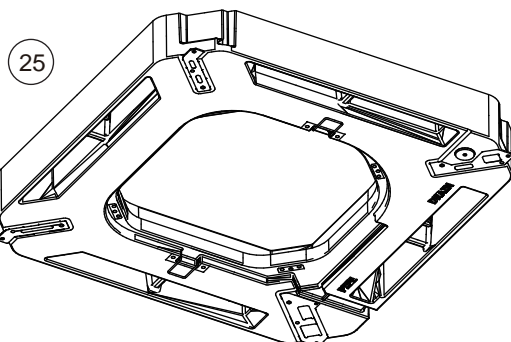
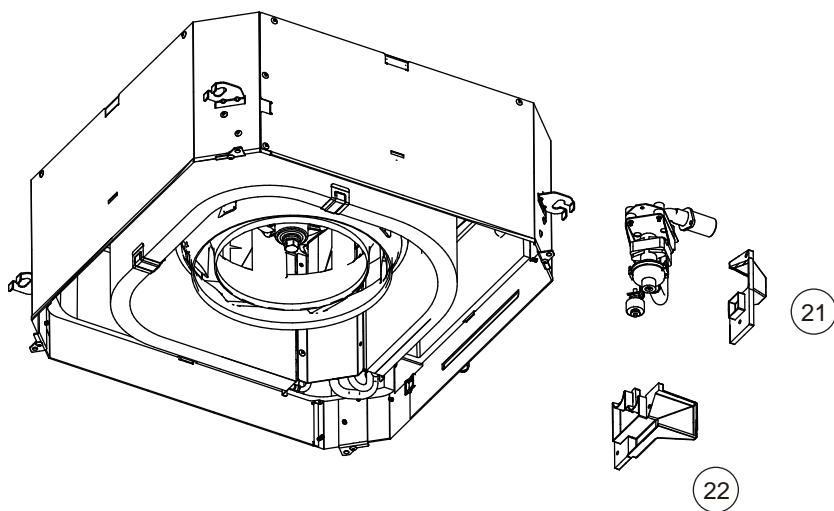

Wire holder

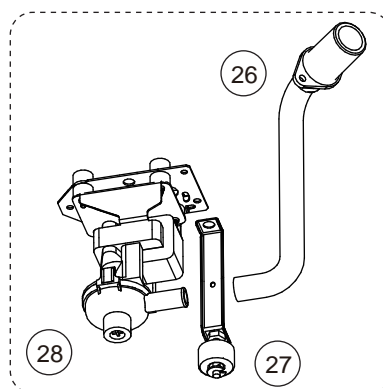

Item no.	Part no.	Part name	Service part
21	9375516017	Wire cover	◆
22	9375515010	Pipe cover	◆
23	9375503017	Bell-mouth hood	◆
24	9375477011	Thermistor holder	◆
25	9377765024	Drain pan sub assy (For 18 model)	◆
26	9375718015	Drain port sub assy	◆
27	9375721046	Float switch sub assy	◆
28	9375717025	Drain pump sub assy	◆

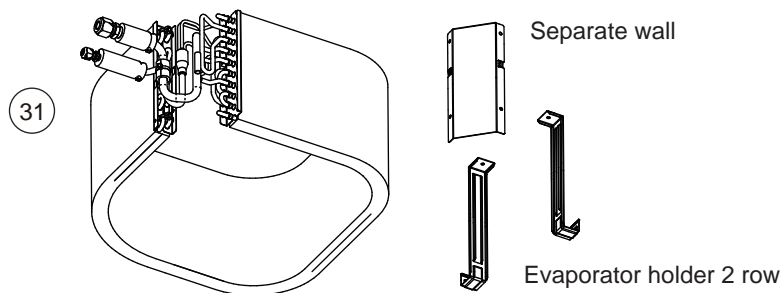
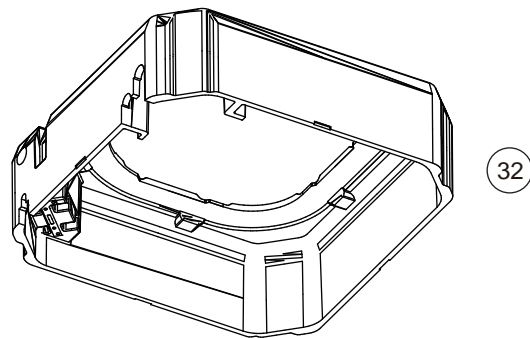
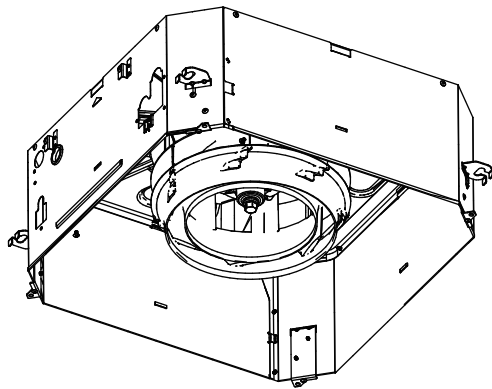

Item no.	Part no.	Part name	Service part
31	9377914156	Evaporator total assy (For 07 model)	◆
	9377914101	Evaporator total assy (For 09, 12 model)	◆
	9377914118	Evaporator total assy (For 14 model)	◆
	9377914125	Evaporator total assy (For 18 model)	◆
32	9377764065	Insulation box sub assy	◆

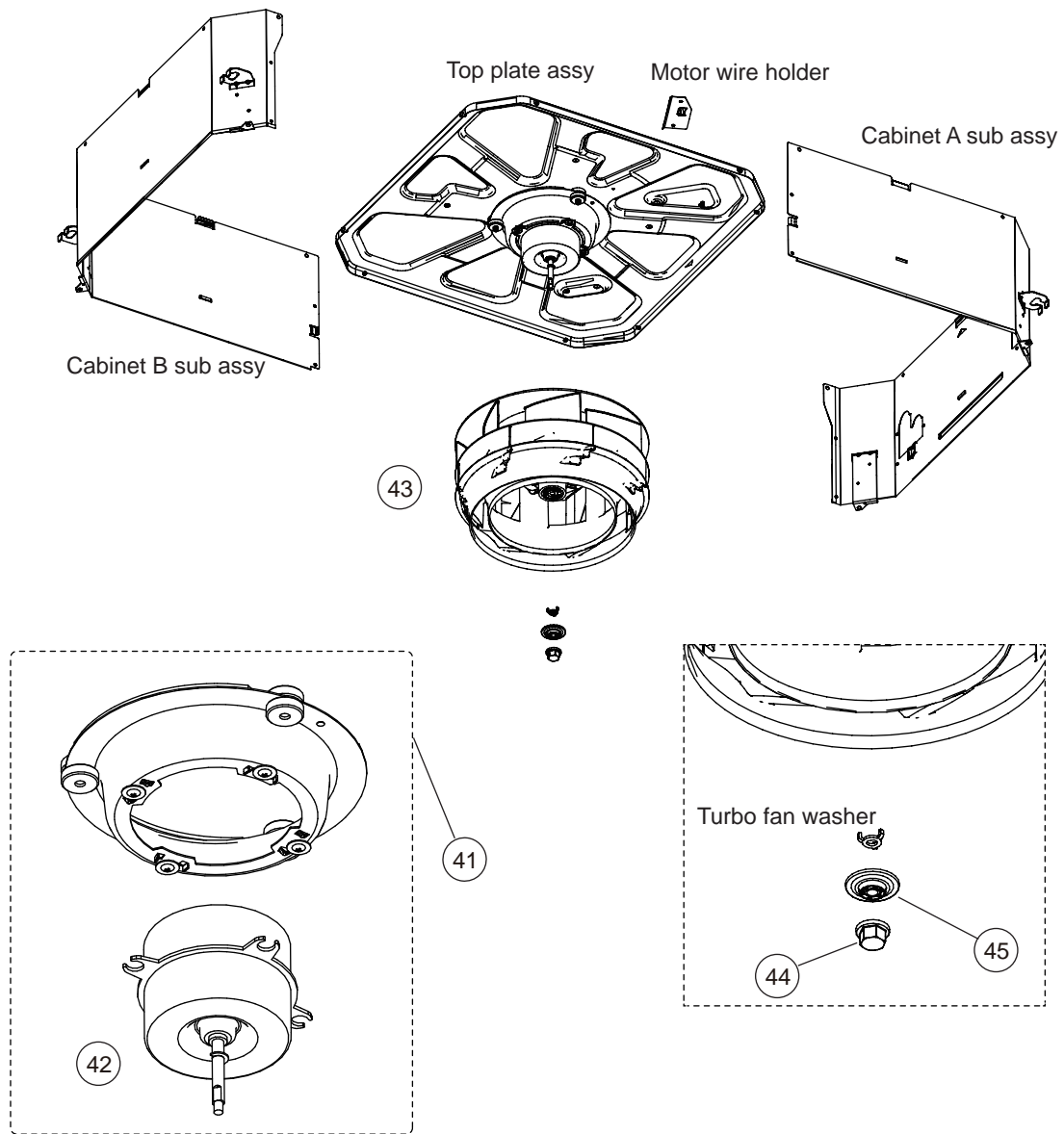

Item no.	Part no.	Part name	Service part
41	9375719012	Fan motor sub Assy	◆
42	9602436019	Fan motor	◆
43	9375480011	2 stage turbo fan Assy	◆
44	9377807014	Shaft cap	◆
45	9377811011	Washer cover	◆

3-2. Mini duct type

■ Models: ARXG07KSLAP, ARXG09KSLAP, ARXG12KSLAP, and ARXG14KSLAP

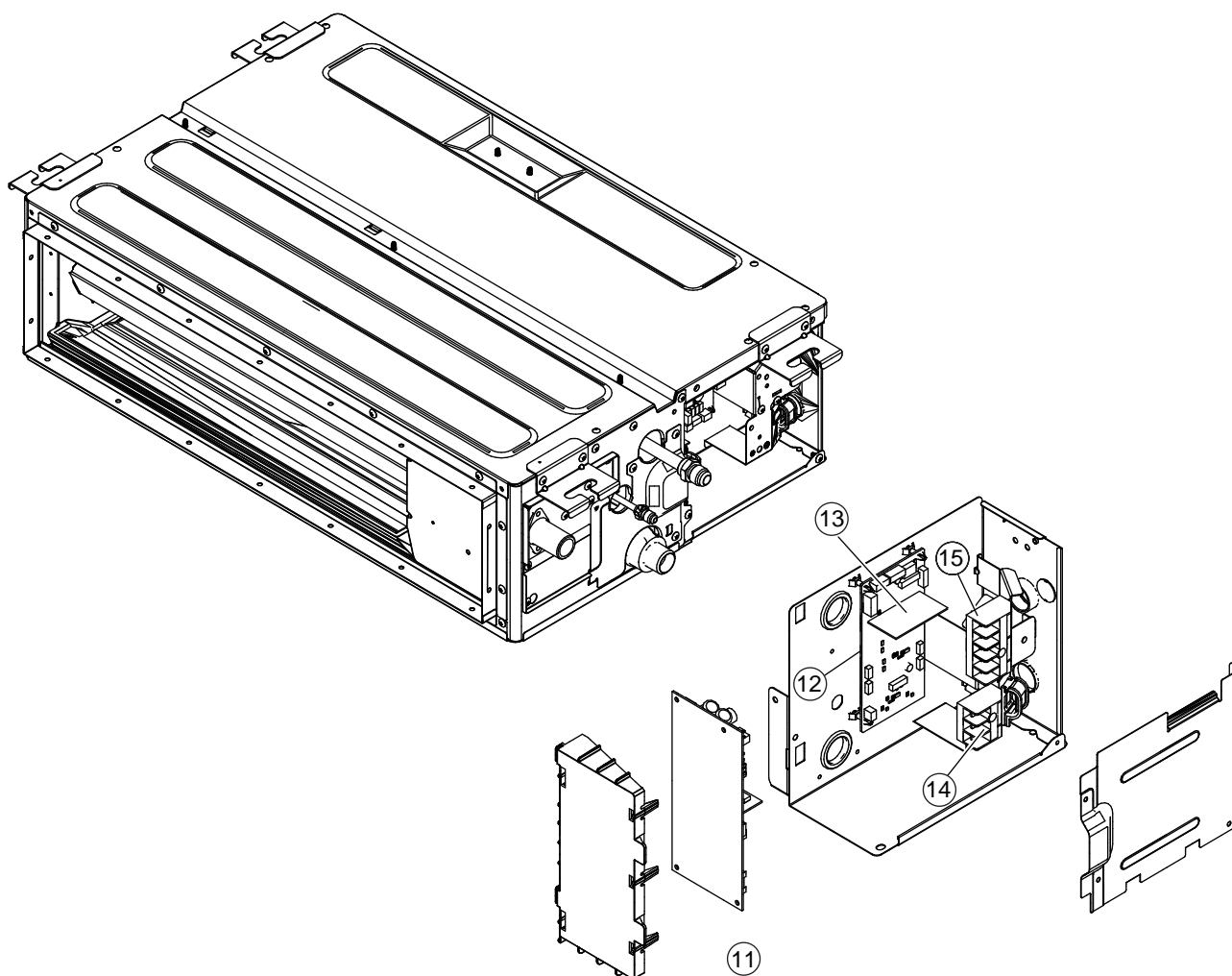

Item no.	Part no.	Part name	Service part
11	9710661020	Power supply PCB	◆
12	9710624261	Main PCB (For 07 model)	◆
	9710624278	Main PCB (For 09 model)	◆
	9710624285	Main PCB (For 12 model)	◆
	9710624292	Main PCB (For 14 model)	◆
13	9710019005	2-way remote PCB	◆
14	9900568009	Terminal 3P	◆
15	9900896003	Terminal 3P (For wired remote controller)	◆
—	9900653033	Room thermistor	◆
—	9900942021	Pipe thermistor	◆

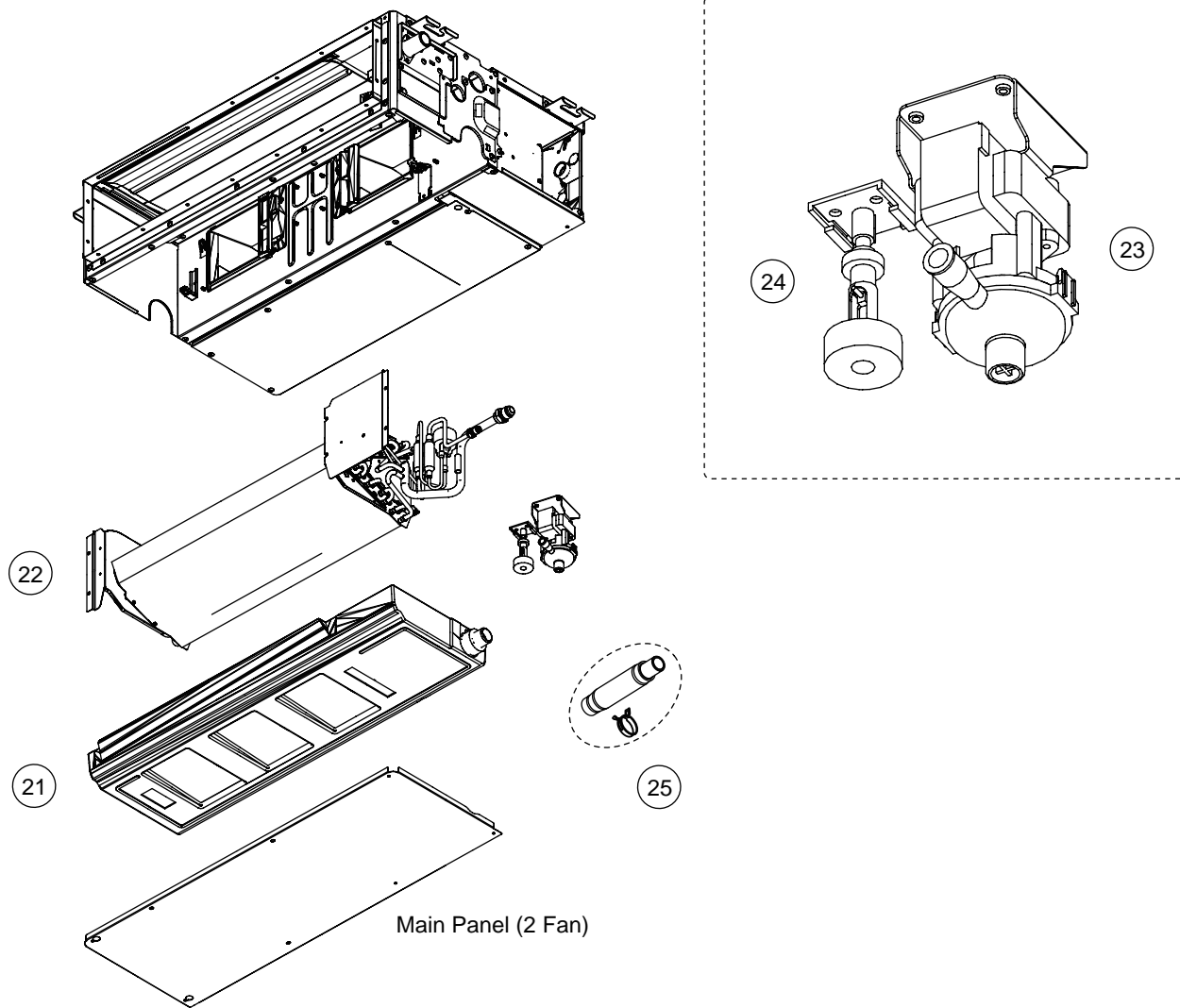

Item no.	Part no.	Part name	Service part
21	9381930111	Drain pan sub assy	◆
22	9381933440	Evaporator total assy	◆
23	9900472061	Pump assy	◆
24	9900465063	Float switch	◆
25	9378450097	Hose sub assy	◆

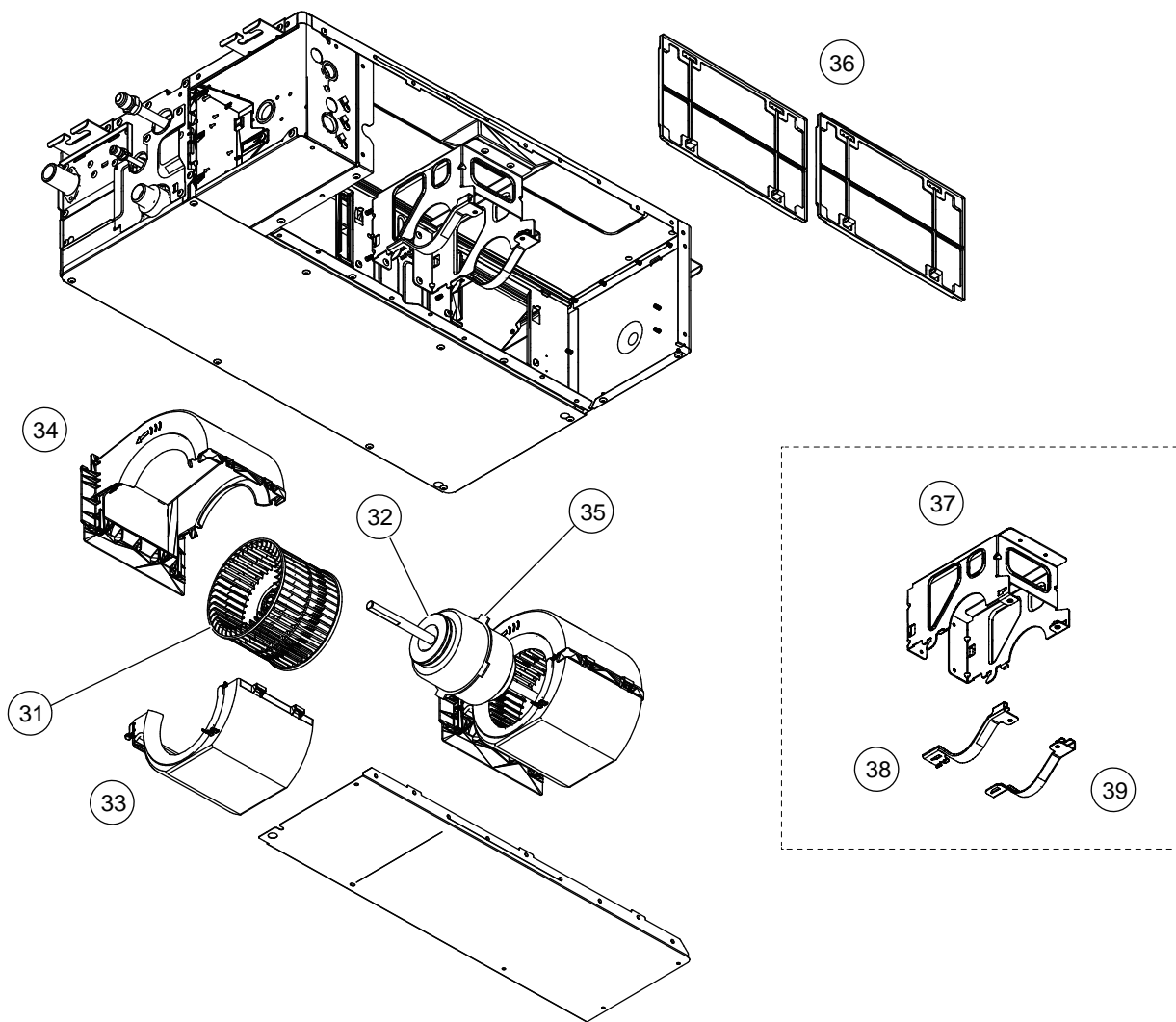

Item no.	Part no.	Part name	Service part
31	9379570015	Sirocco fan assy	◆
32	9381673001	Rubber (Vibration proof)	◆
33	9381676002	Casing B	◆
34	9381677016	Casing U	◆
35	9380636038	Fan motor assy (For 07 model)	◆
36	9379574006	Air filter	◆
37	9381675005	Motor bracket assy	◆
38	9381669004	Motor band L	◆
39	9381670000	Motor band R	◆

■ Model: ARXG18KSLAP

● Chassis

TECHNICAL DATA
AND PARTS LIST

TECHNICAL DATA
AND PARTS LIST

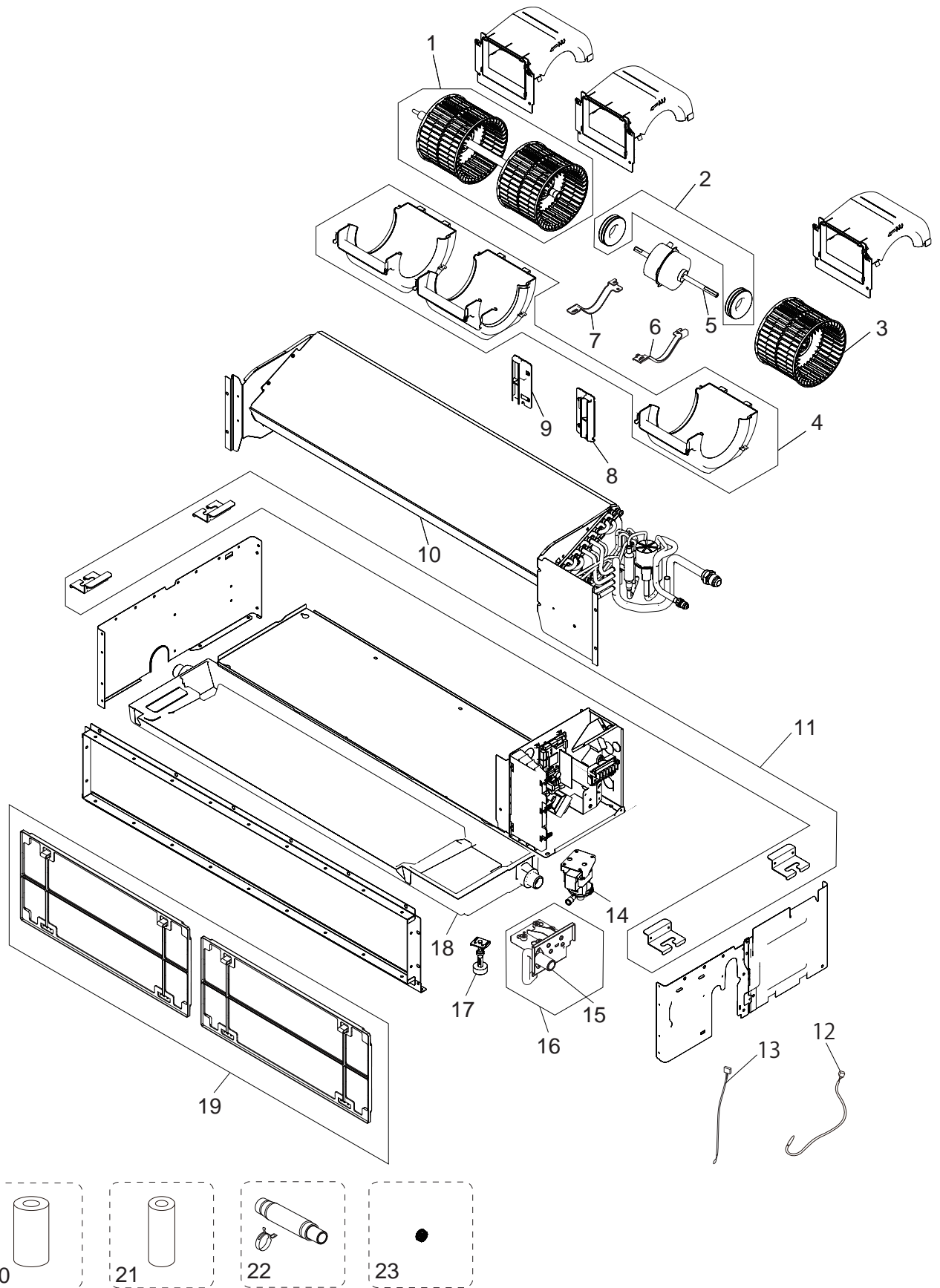

Item no.	Part no.	Part name	Service part
1	9379971065	Sirroco fan sub assy	◆
2	9383443008	Rubber vibration proof assy	◆
3	9379570022	Sirroco fan assy	◆
4	9381676002	Casing B	◆
5	9379047128	Motor band L	◆
6	9381669004	Motor band L	◆
7	9381670000	Motor band R	◆
8	9381831005	Air guide L	◆
9	9381832002	Air guide R	◆
10	9381933624	Evaporator total assy	◆
11	9381659005	Hook metal	◆
12	9900653033	Thermistor (room)	◆
13	9900349011	Thermistor (pipe)	◆
14	9900472061	Pump assy	◆
15	9381928002	Drain hose assy	◆
16	9381927005	Drain pump panel sub assy	◆
17	9900465063	Float switch	◆
18	9381930104	Drain pan sub assy	◆
19	9379575003	Air filter	◆
20	9378173569	Insulation pipe C	◆
21	9378173521	Insulation pipe D	◆
22	9378450097	Hose sub assy	◆
23	9357921006	Bearing B assy	◆

● Inverter unit

TECHNICAL DATA
AND PARTS LIST

TECHNICAL DATA
AND PARTS LIST

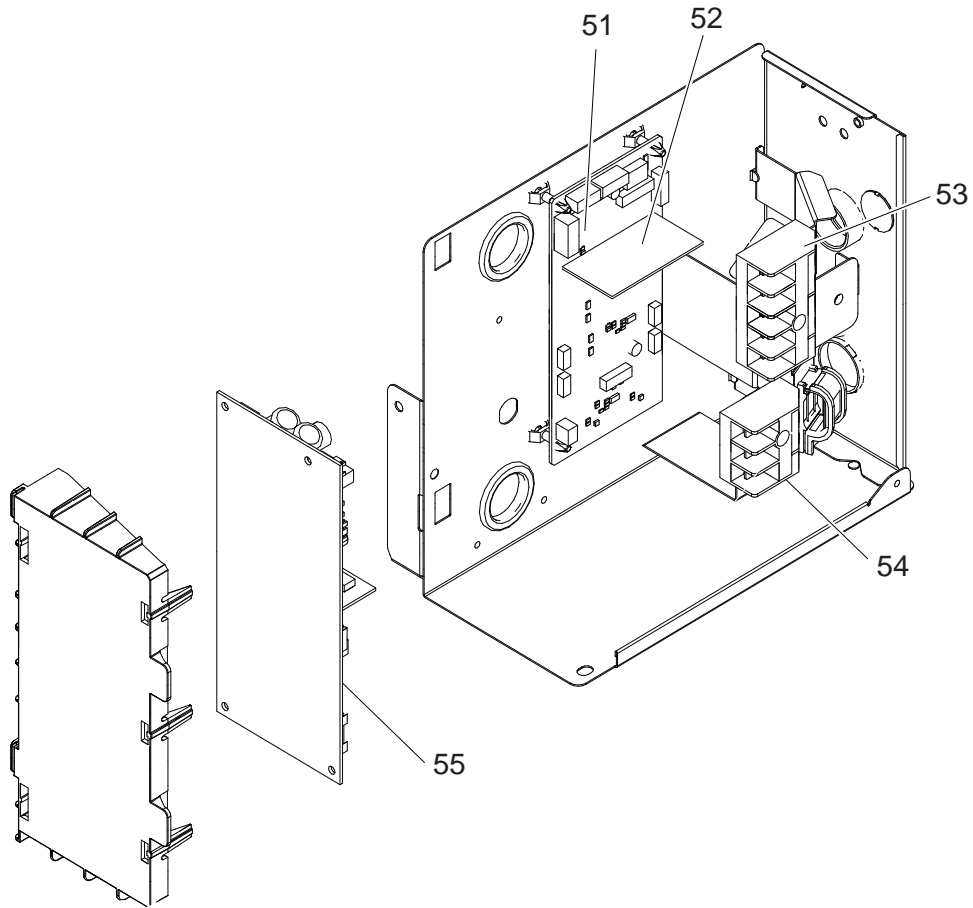

Item no.	Part no.	Part name	Service part
51	9710624315	Main PCB	◆
52	9710019005	2way remote PCB	◆
53	9900896003	Terminal (remote control)	◆
54	9900568009	Terminal (power)	◆
55	9710661020	Power PCB	◆
—	9710177057	Wire with connector (CN46—External input)	◆
—	9710173066	Wire with connector (CN300—Remote terminal)	◆
—	9710703010	Wire with connector (CN205—Power)	◆
—	9710171055	Wire with connector (CN262—CN260)	◆
—	9710206047	Wire with connector (CN263—CN261)	◆

3-3. Slim duct type

■ Models: ARXG07KLLAP, ARXG09KLLAP, ARXG12KLLAP, and ARXG14KLLAP

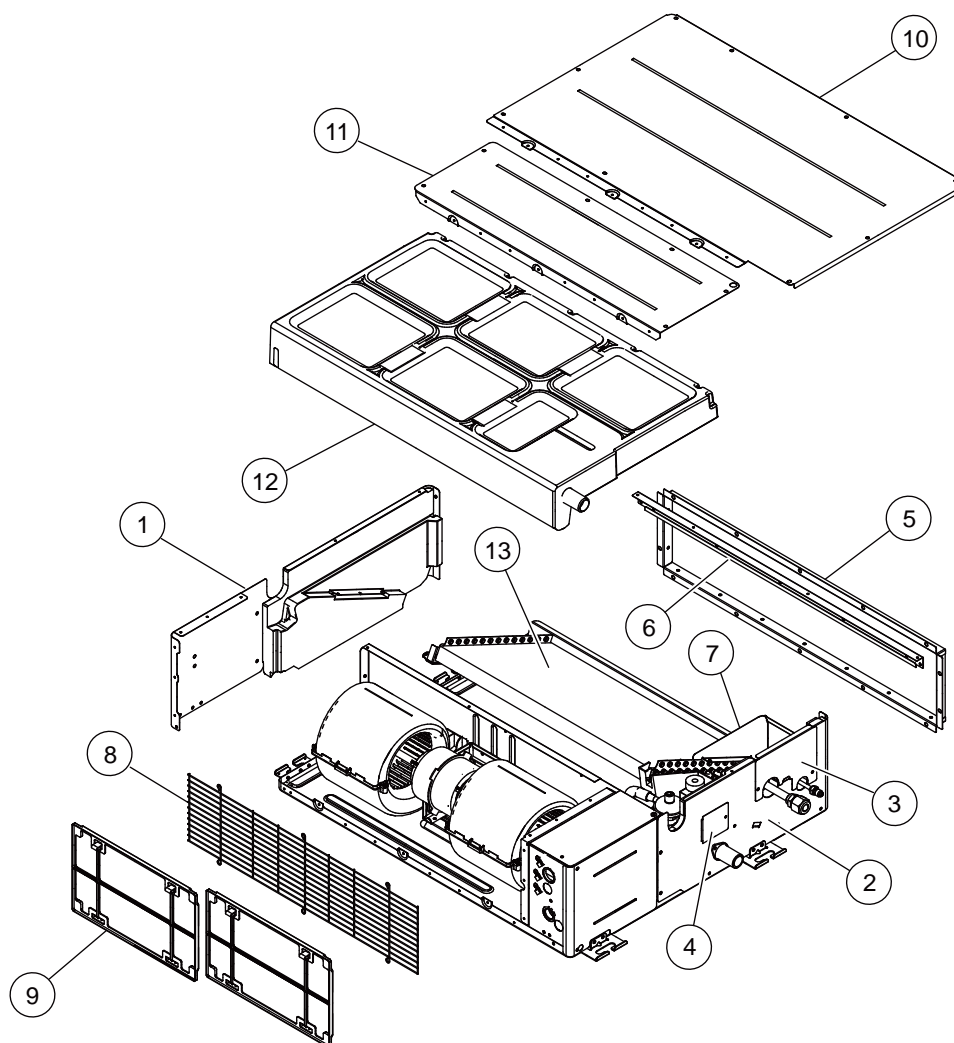

Item no.	Part no.	Part name	Service part
1	9379906012	Side panel R sub assy	◆
2	9379907019	Side panel L sub assy	◆
3	9379900003	Pipe panel sub assy	◆
4	9379915007	Panel (Window) sub assy	◆
5	9380042006	Outlet frame assy	◆
6	9380594000	Front panel (2-fan)	◆
7	9379576017	Valve cover sub assy	◆
8	9380589006	Fan guard (2-fan)	◆
9	9379574006	Air filter	◆
10	9380602019	Main panel (2-fan)	◆
11	9380597001	Cabinet panel (2-fan)	◆
12	9381209002	Drain pan sub assy	◆
13	9380682509	Evaporator total assy (For 07 model)	◆
	9380682486	Evaporator total assy (For 09, 12, 14 model)	◆

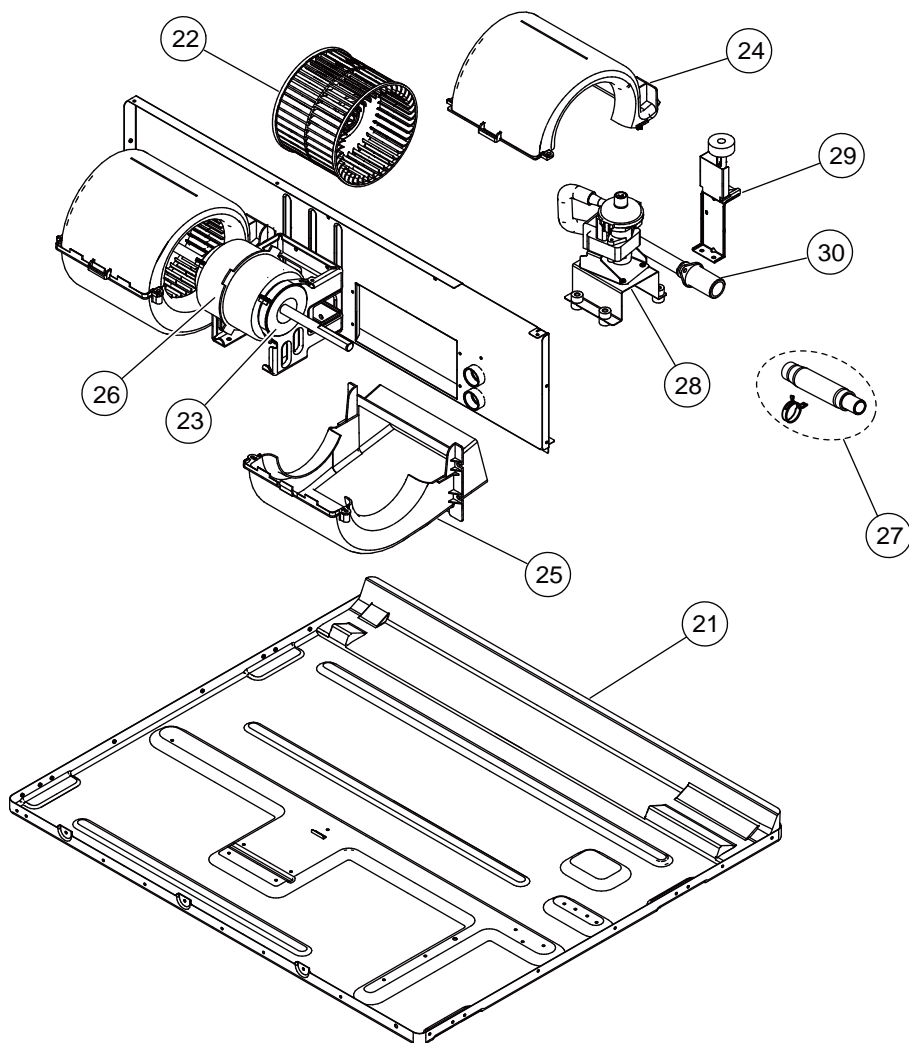

Item no.	Part no.	Part name	Service part
21	9379908030	Total panel sub assy	◆
22	9379570015	Sirocco fan assy	◆
23	9379644006	Rubber (Vibration proof)	◆
24	9379572019	Casing B	◆
25	9379571012	Casing U	◆
26	9379047166	Fan motor assy (For 07 model)	◆
	9379047159	Fan motor assy (For 09, 12, 14 model)	◆
27	9378450097	Hose sub assy	◆
28	9379914062	Drain pump sub assy	◆
29	9378593039	Float switch sub assy	◆
30	9379913003	Drain hose assy	◆

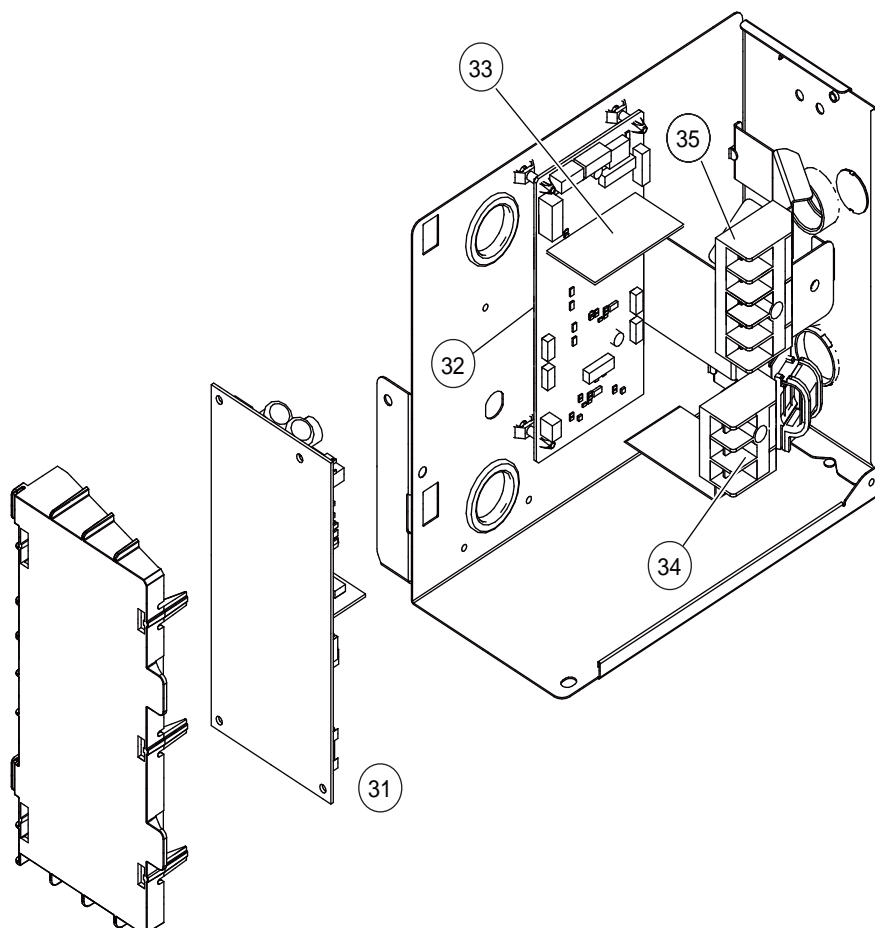

Item no.	Part no.	Part name	Service part
31	9710661006	Power supply PCB	◆
32	9710624308	Main PCB (For 07 model)	◆
	9710624209	Main PCB (For 09 model)	◆
	9710624216	Main PCB (For 12 model)	◆
	9710624148	Main PCB (For 14 model)	◆
33	9710019005	2-way remote PCB	◆
34	9900568009	Terminal 3P	◆
35	9900896003	Terminal 3P (For wired remote controller)	◆
—	9900653019	Room thermistor	◆
—	9900942045	Pipe thermistor	◆

Model: ARXG18KLLAP

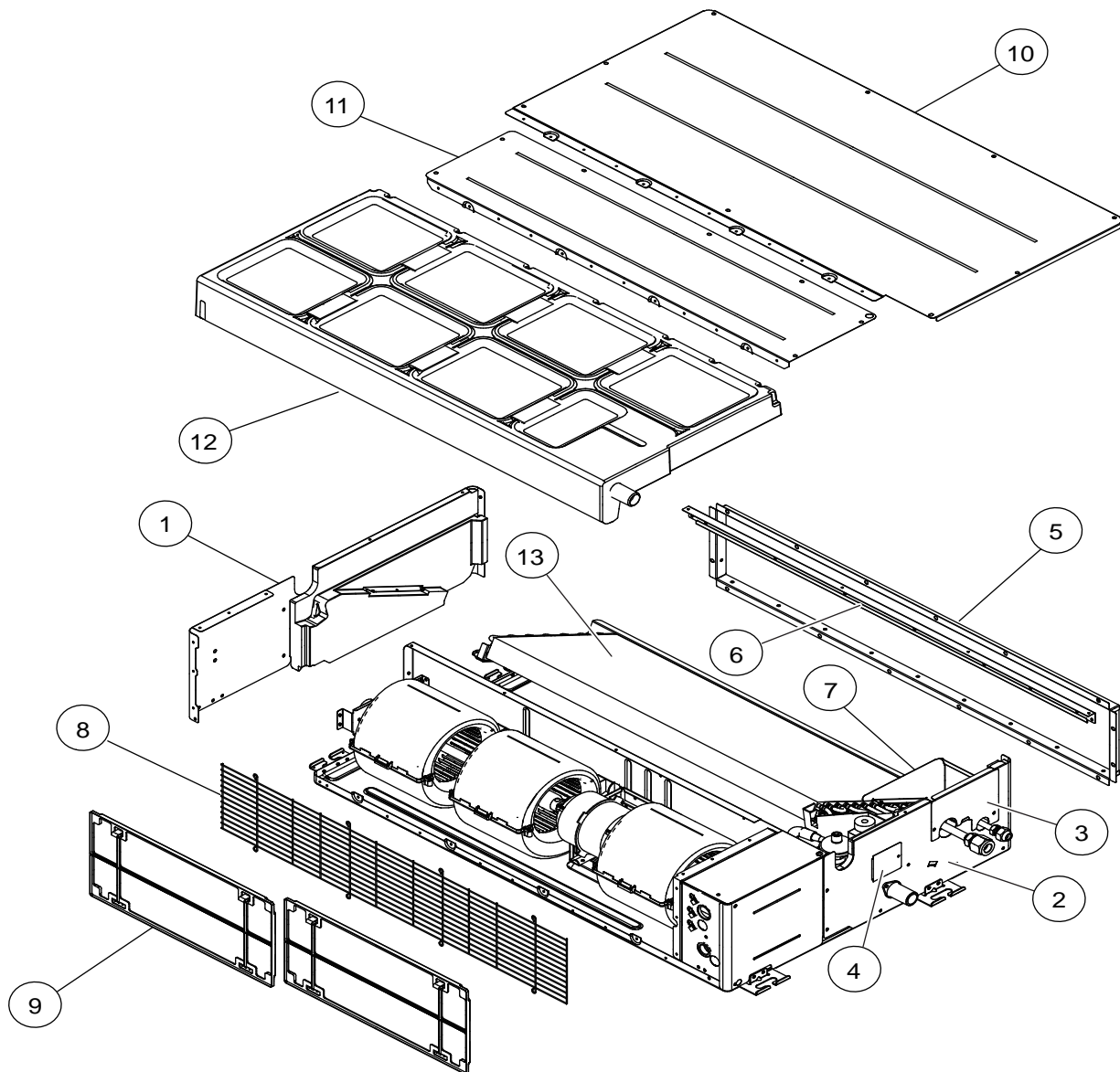

Item no.	Part no.	Part name	Service part
1	9379906012	Side panel R sub assy	◆
2	9379907019	Side panel L sub assy	◆
3	9379900003	Pipe panel sub assy	◆
4	9379915007	Panel (Window) sub assy	◆
5	9380042013	Outlet frame assy	◆
6	9380595007	Front panel (3-fan)	◆
7	9379576017	Valve cover sub assy	◆
8	9380590002	Fan guard (3-fan)	◆
9	9379575003	Air filter	◆
10	9380603016	Main panel (3-fan)	◆
11	9380598008	Cabinet panel (3-fan)	◆
12	9379901178	Drain pan sub assy	◆
13	9380682493	Evaporator total assy	◆

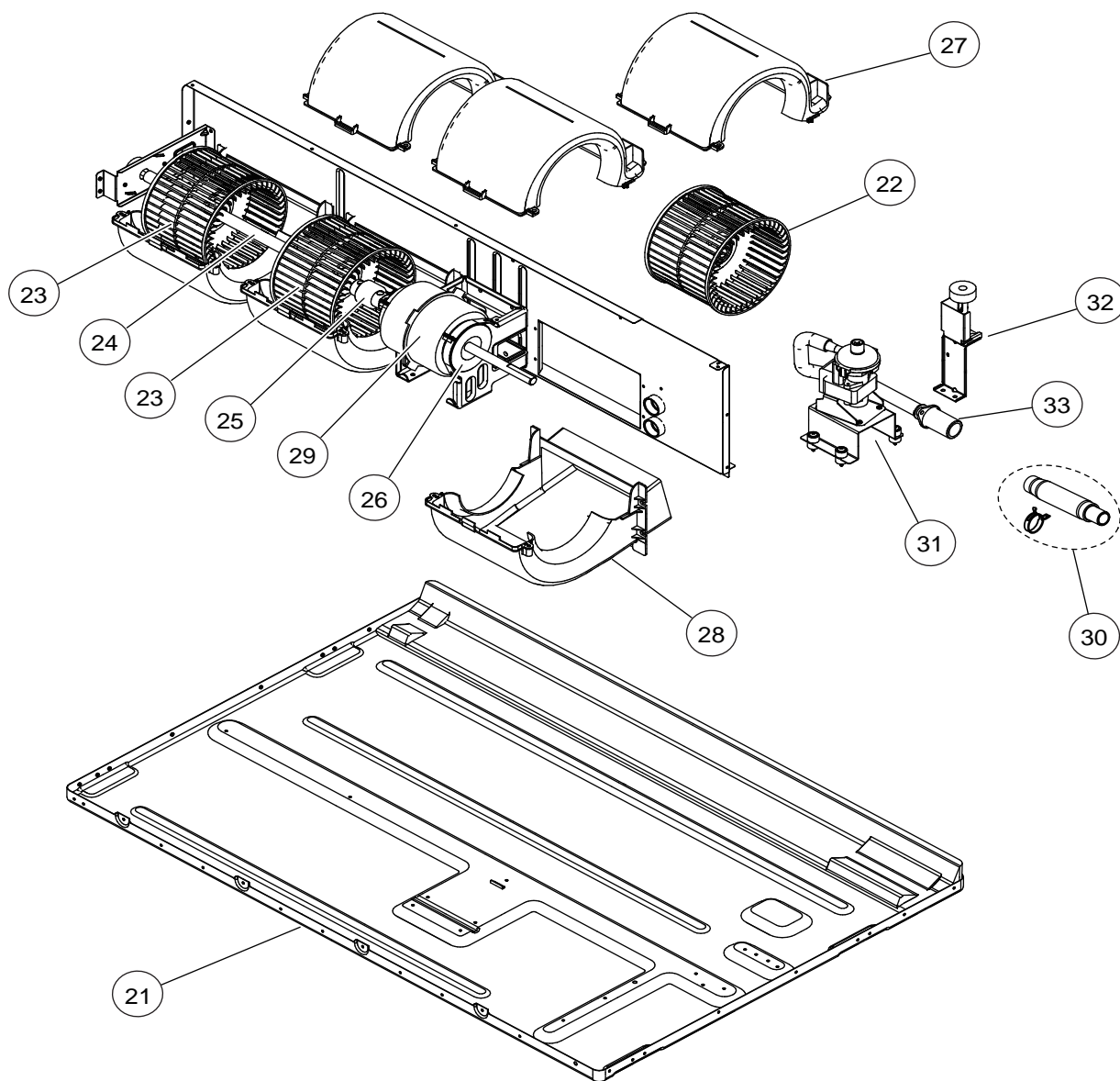

Item no.	Part no.	Part name	Service part
21	9379908047	Total panel sub assy	◆
22	9379570022	Sirocco fan assy	◆
23	9379570039	Sirocco fan assy	◆
23	9381052004	Shaft assy	◆
23	9378038011	Joint assy	◆
23	9379644006	Rubber (Vibration proof)	◆
24	9379572019	Casing B	◆
25	9379571012	Casing U	◆
26	9379047142	Fan motor assy	◆
27	9378450097	Hose sub assy	◆
28	9379914062	Drain pump sub assy	◆
29	9378593039	Float switch sub assy	◆
30	9379913003	Drain hose assy	◆

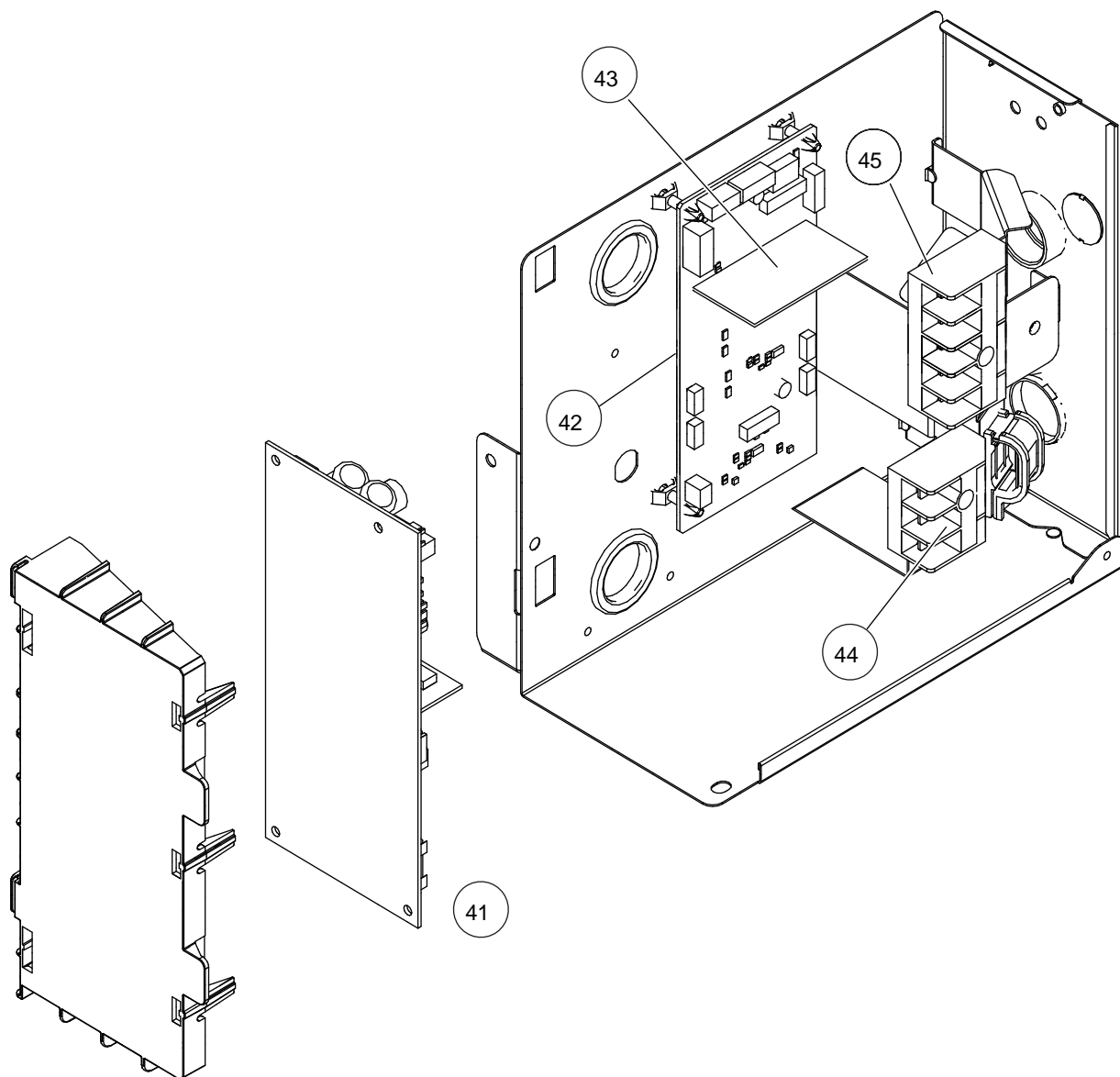

Item no.	Part no.	Part name	Service part
31	9710661006	Power supply PCB	◆
32	9710624131	Main PCB	◆
33	9710019005	2-way remote PCB	◆
34	9900568009	Terminal 3P	◆
35	9900896003	Terminal 3P (For wired remote controller)	◆
—	9900653019	Room thermistor	◆
—	9900942045	Pipe thermistor	◆

3-4. Wall mounted type

■ Models: ASYG07KGTB, ASYG09KGTB, ASYG12KGTB, and ASYG14KGTB

● Exterior parts and chassis

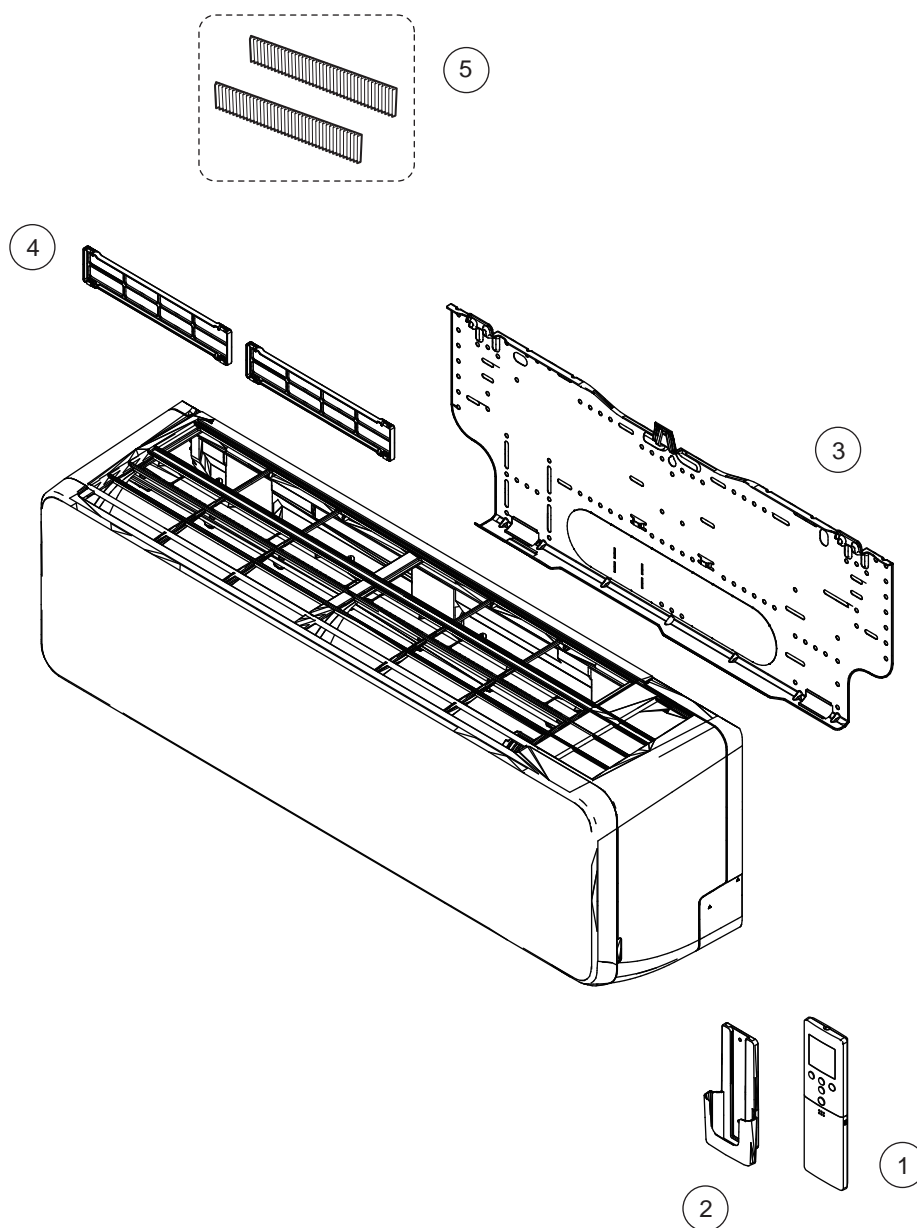

Item no.	Part no.	Part name	Service part
1	9382108045	Remote control	◆
2	9318912005	Remote control holder	◆
3	9387480009	Bracket panel	◆
4	9332911008	Electric filter holder	◆
5	9317250009	Air clean filter assy	◆

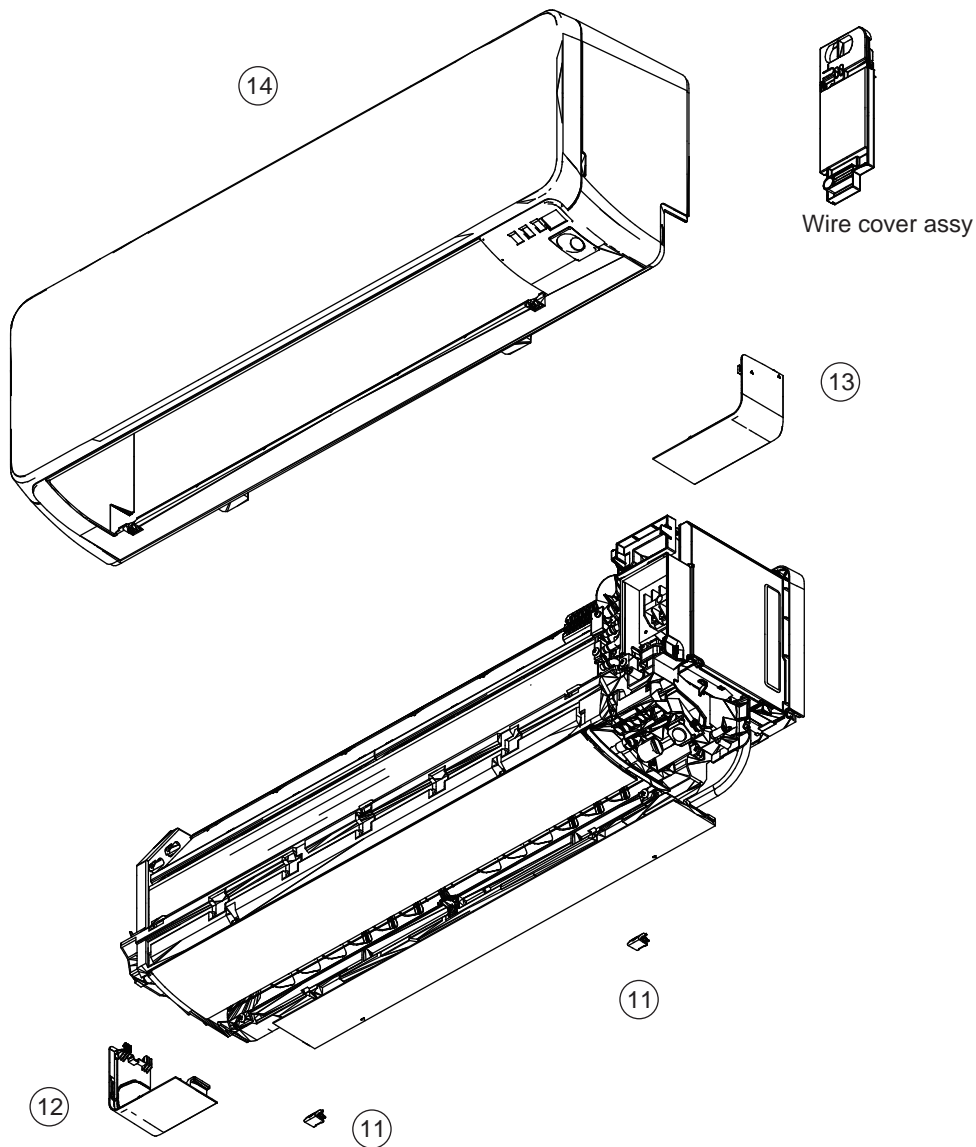

Item no.	Part no.	Part name	Service part
11	9387476002	Screw cap	◆
12	9387477009	Under cover L	◆
13	9387478006	Under cover R	◆
14	9387596007	Front panel total assy	◆

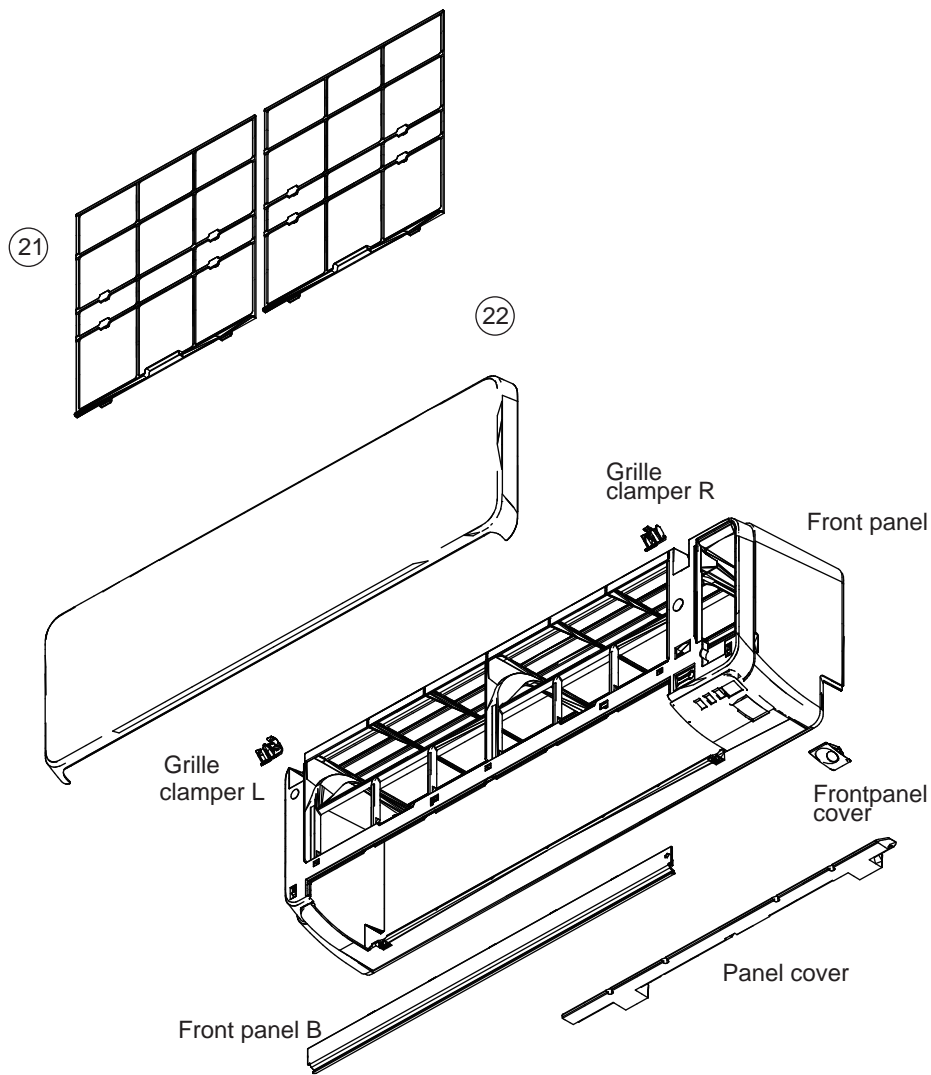

Item no.	Part no.	Part name	Service part
21	9387473001	Air filter	◆
22	9387756005	Intake grille assy	◆

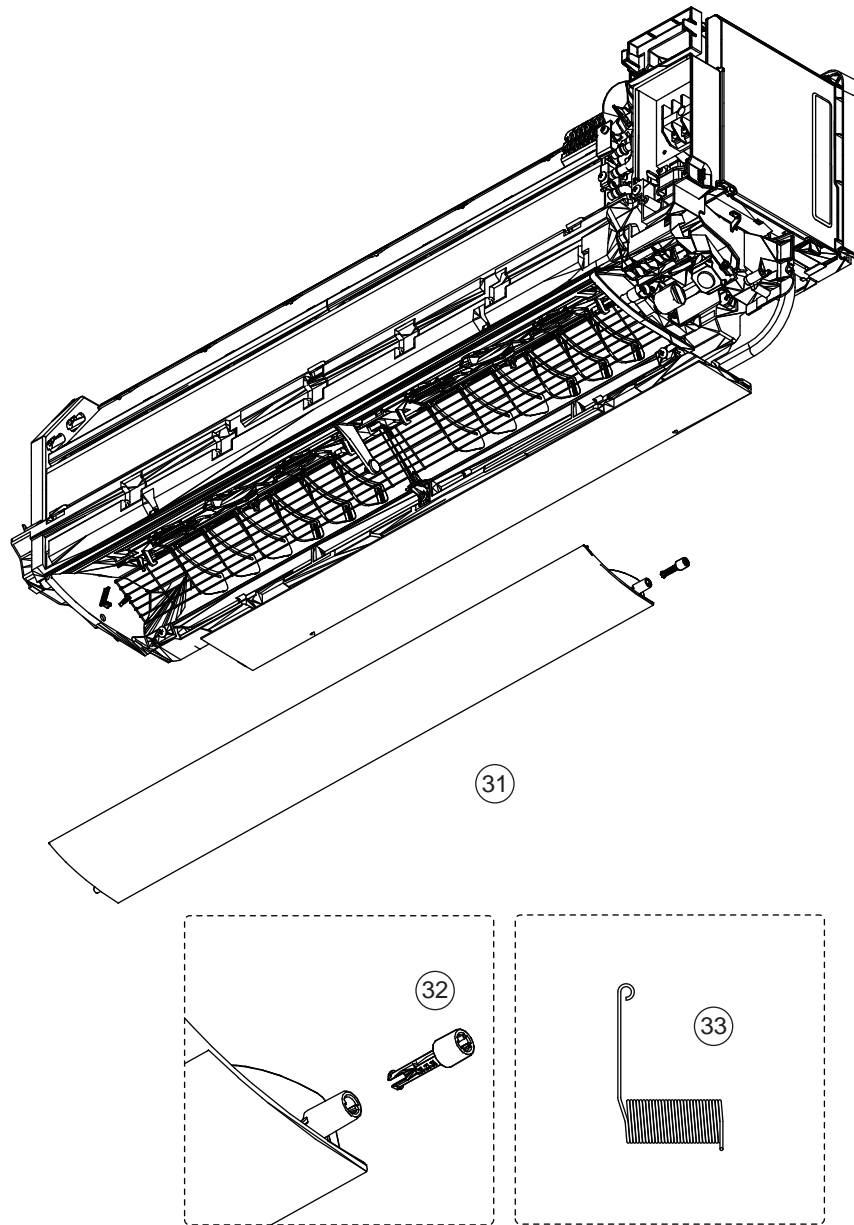

Item no.	Part no.	Part name	Service part
31	9387479003	U/D louver assy	◆
32	9332861006	Shaft cover	◆
33	9387471007	Louver spring	◆

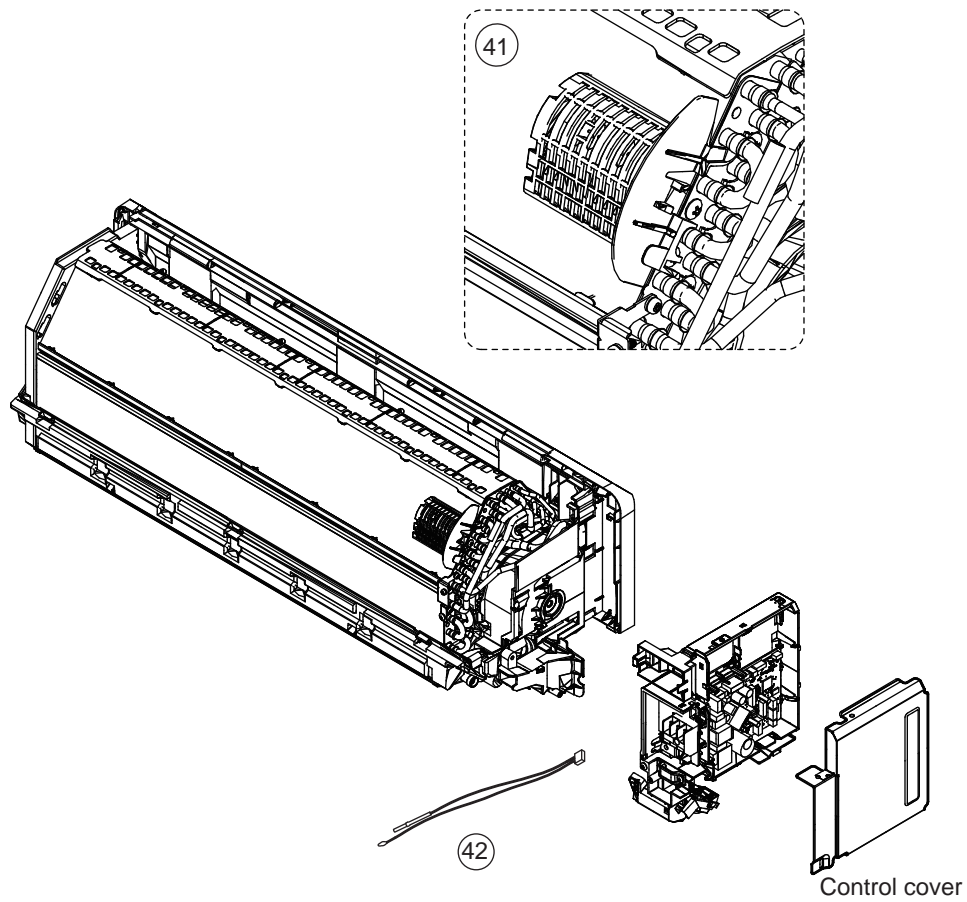

Item no.	Part no.	Part name	Service part
41	9387467000	Room Thermistor Holder	◆
42	9900627041	Thermistor Assy	◆

● Control box

TECHNICAL DATA
AND PARTS LIST

TECHNICAL DATA
AND PARTS LIST

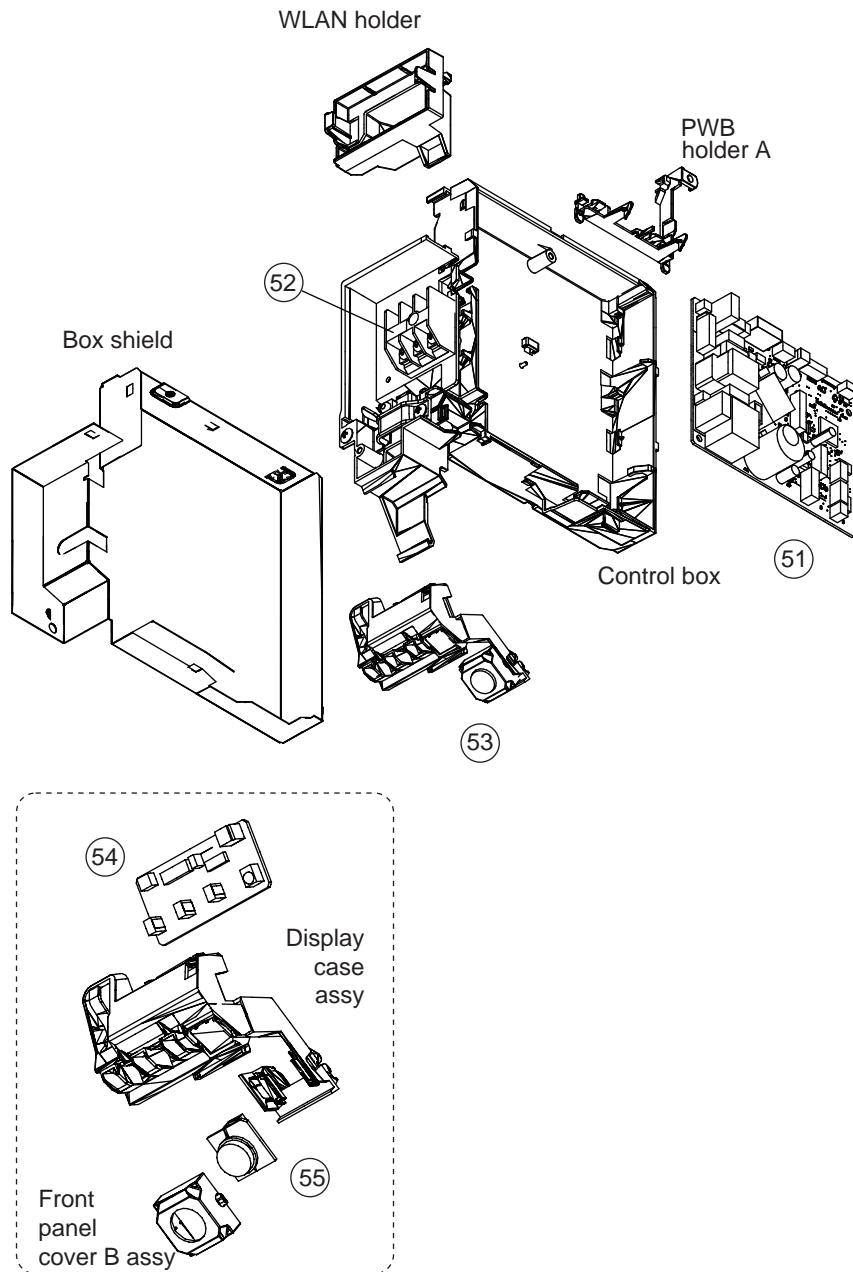

Item no.	Part no.	Part name	Service part
51	9710782411	Main PCB (for 07 model)	◆
	9710782428	Main PCB (for 09 model)	◆
	9710782435	Main PCB (for 12 model)	◆
	9710782442	Main PCB (for 14 model)	◆
52	9306489045	Terminal	◆
53	9710858017	Display Assy	◆
54	9710786013	Indicator PCB	◆
55	9317755061	Pyroelectric sensor	◆

● Evaporator

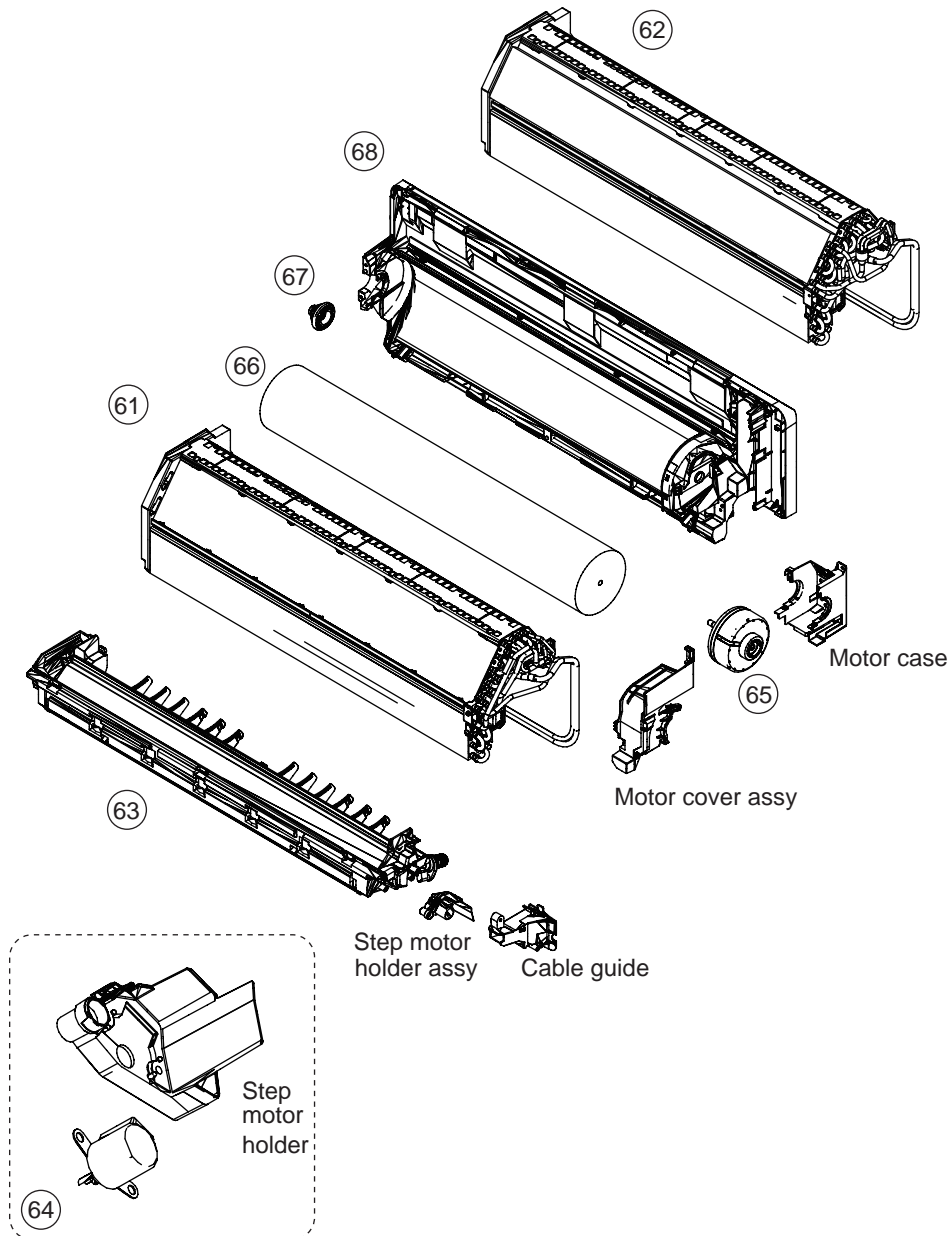

Item no.	Part no.	Part name	Service part
61	9387593143	Evaporator total assy (for 07, 09, 12 model)	◆
62	9387593150	Evaporator total assy (for 14 model)	◆
63	9387590005	Drain pan total assy	◆
64	9387714005	Step motor holder assy	◆
65	9603569013	Brushless motor (for 07, 09, 12 model)	◆
	9603572013	Brushless motor (for 14 model)	◆
66	9387055016	Crossflow fan assy	◆
67	9333628004	Bearing D assy	◆
68	9387587012	Base assy	◆

■ Model: ASYG18KMTB

TECHNICAL DATA
AND PARTS LIST

TECHNICAL DATA
AND PARTS LIST

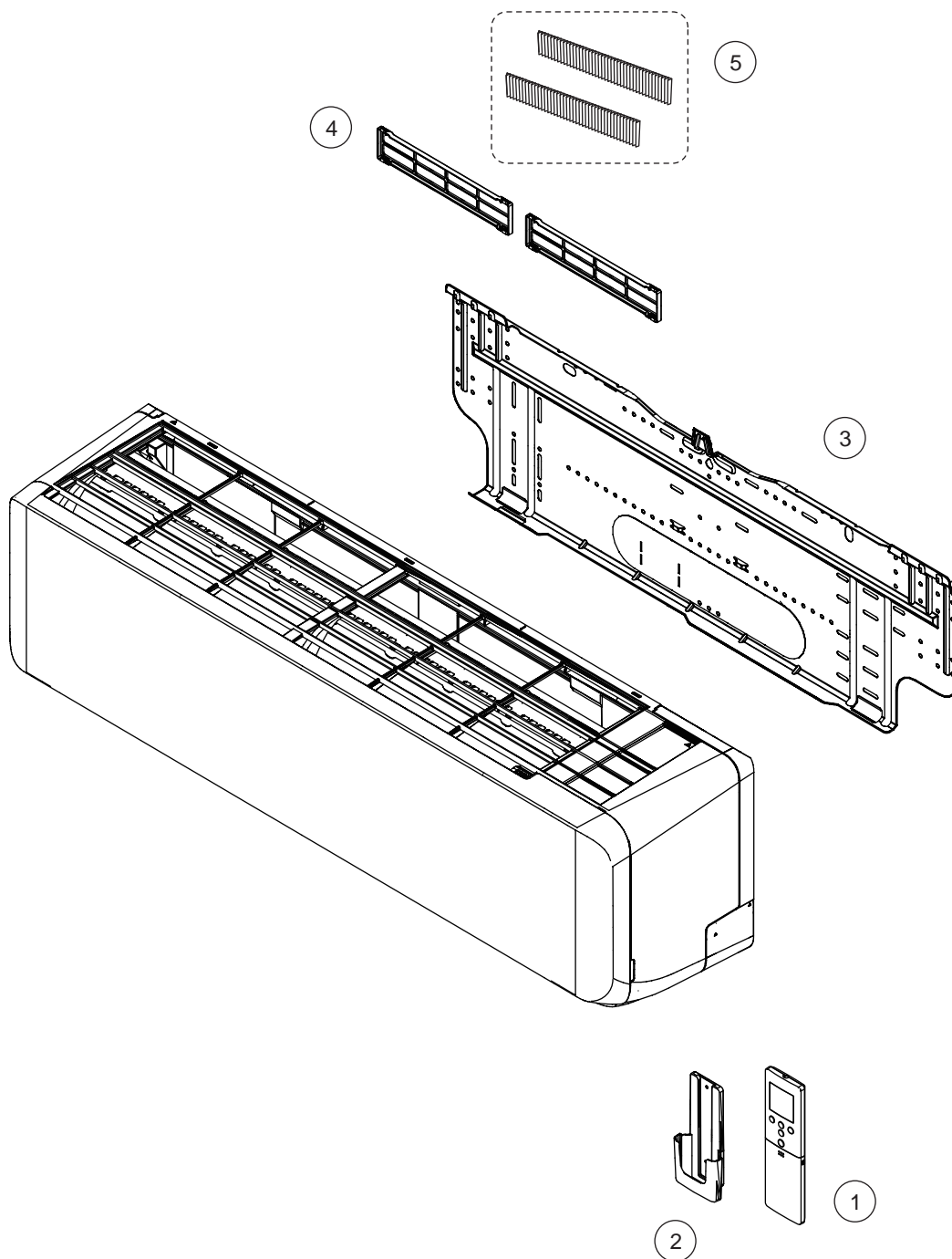

Item no.	Part no.	Part name	Service part
1	9383712012	Remote controller	◆
2	9318912005	Remote controller holder	◆
3	9323351004	Bracket panel	◆
4	9332911008	Electric filter holder	◆
5	9317250009	Air clean filter assy	◆

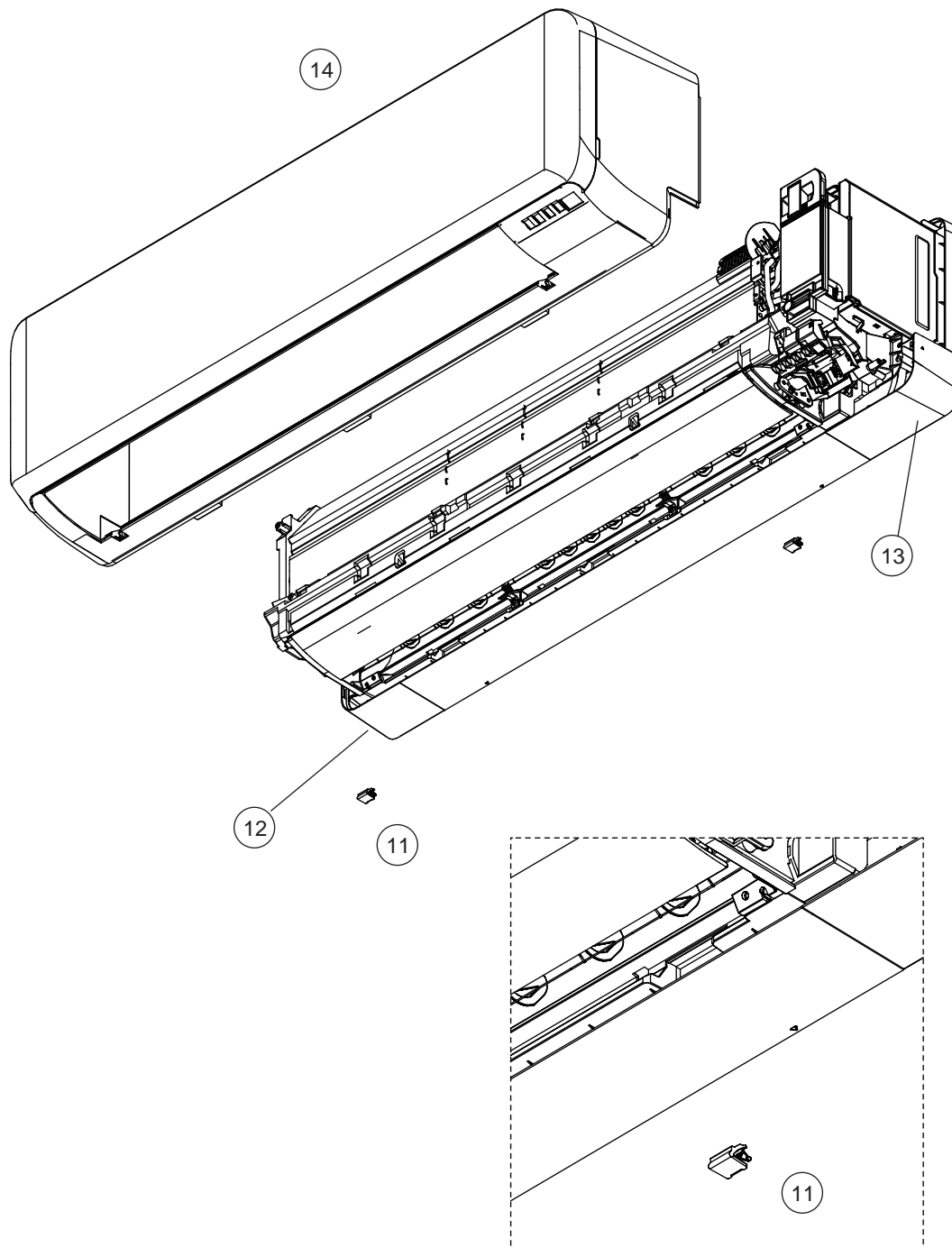

Item no.	Part no.	Part name	Service part
11	9387476002	Screw cap	◆
12	9323341012	Under cover L	◆
13	9323342019	Under cover R	◆
14	9387596618	Front panel total assy	◆

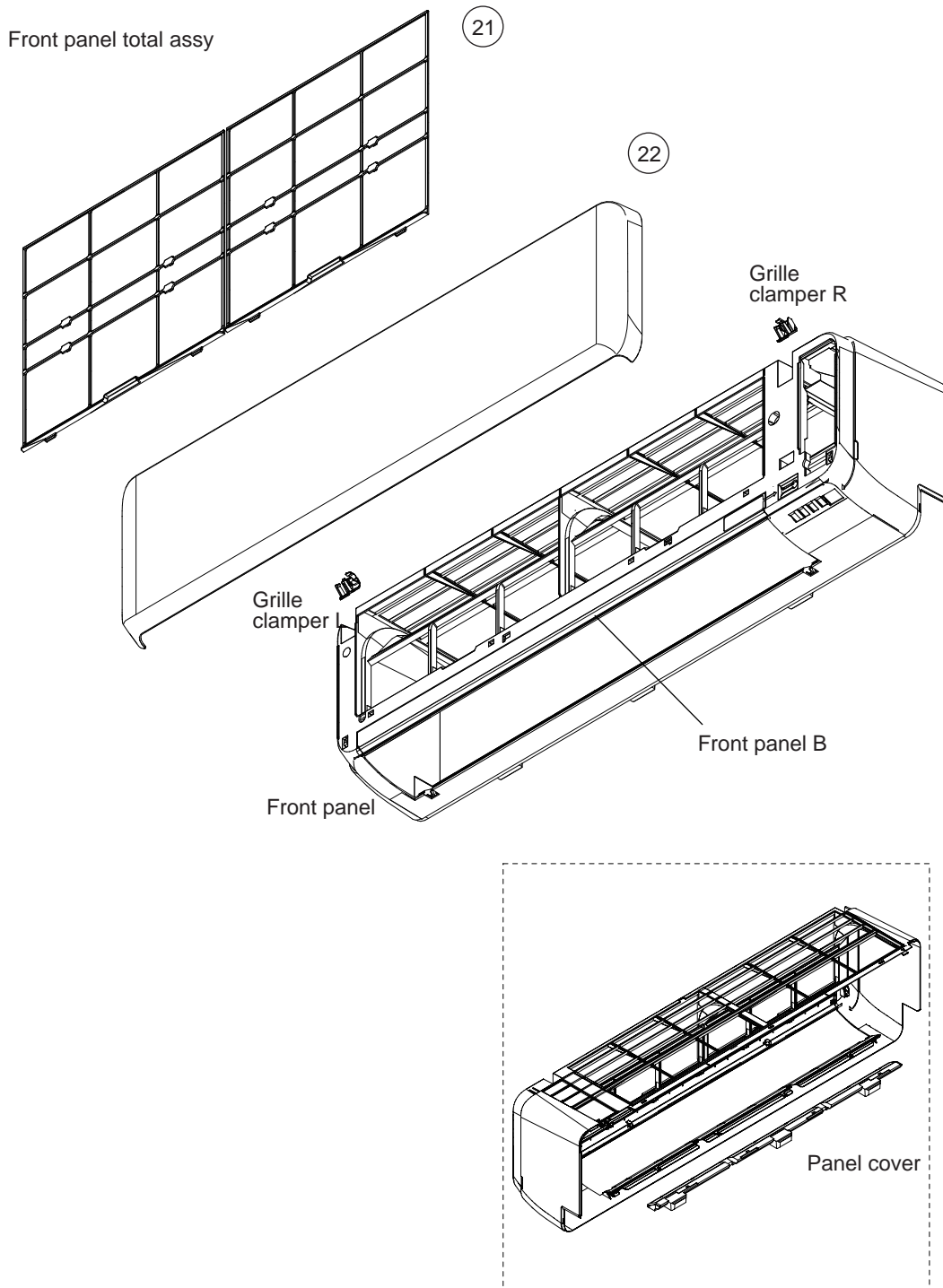

Item no.	Part no.	Part name	Service part
21	9323340008	Air filter	◆
22	9387756067	Intake grille assy	◆

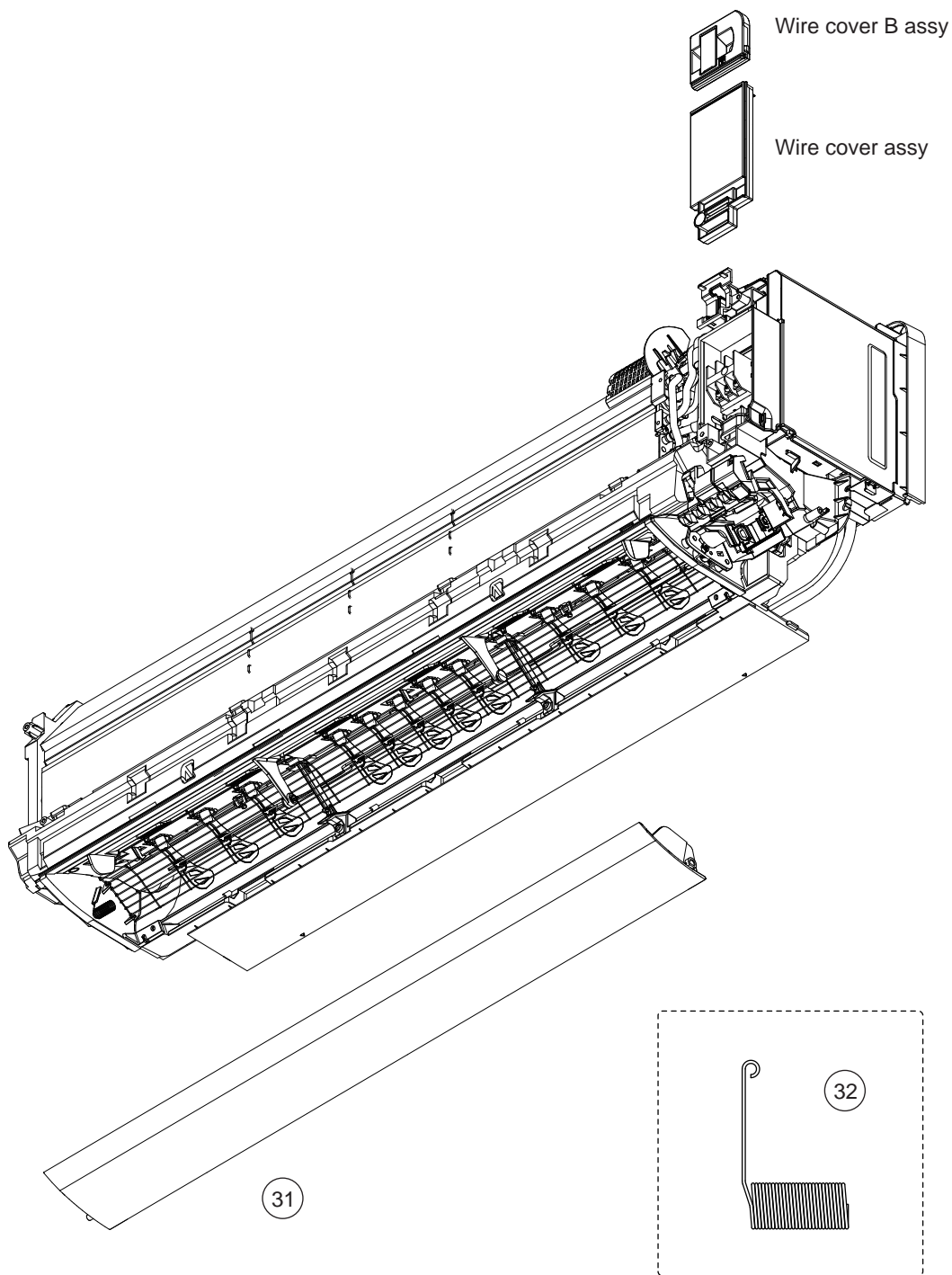

Item no.	Part no.	Part name	Service part
31	9387479010	U/D louver assy	◆
32	9383730030	Louver spring	◆

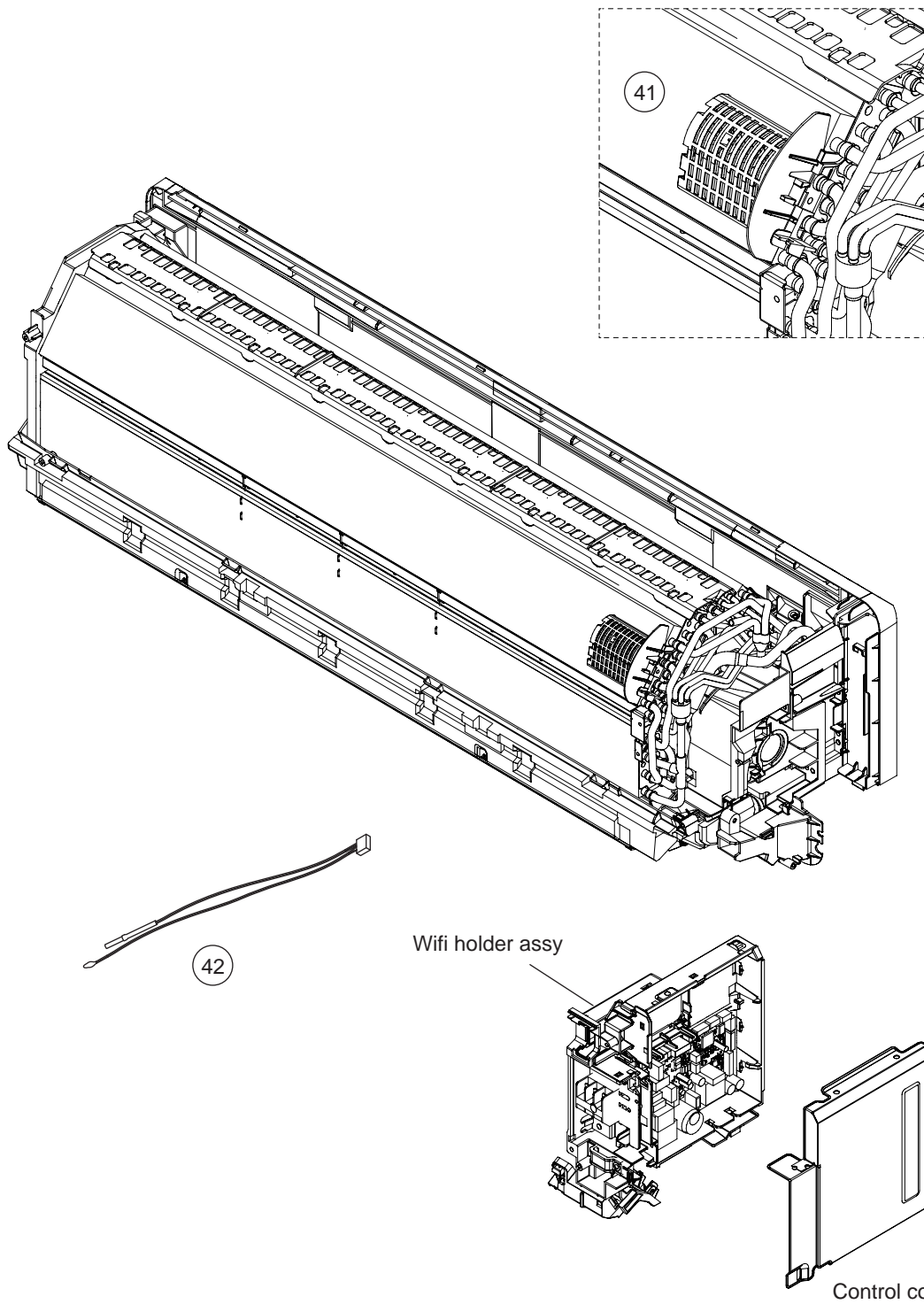

Item no.	Part no.	Part name	Service part
41	9387467000	Room thermistor holder	◆
42	9900627041	Thermistor assy	◆

Control box

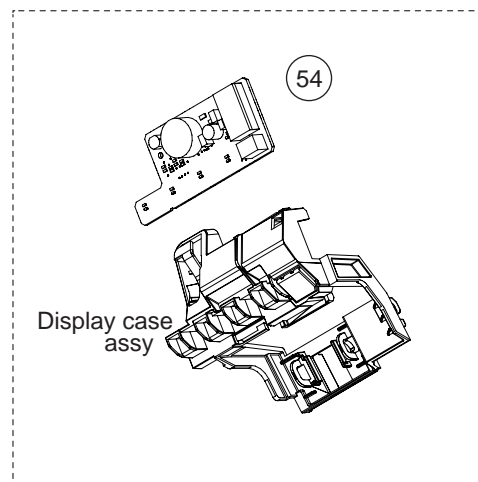
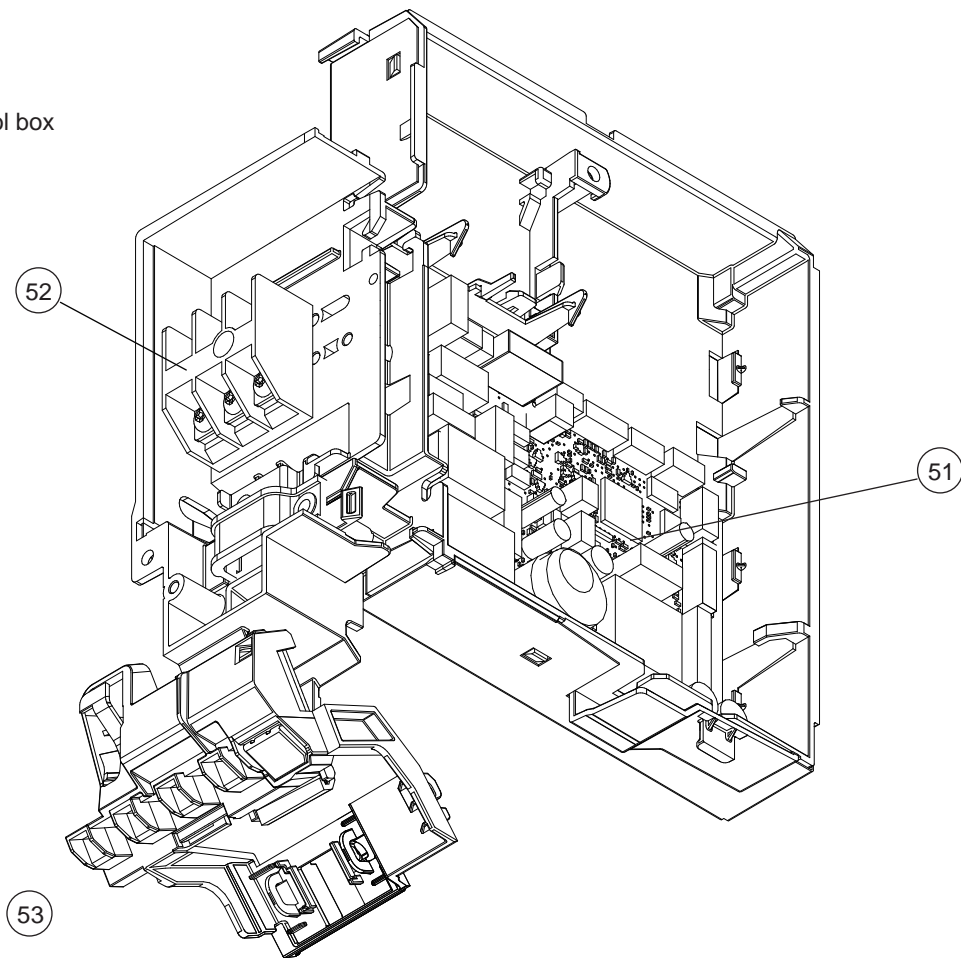

Item no.	Part no.	Part name	Service part
51	9711141538	Main PCB	◆
52	9306489045	Terminal	◆
53	9711146052	Display assy	◆
54	9711147011	Indicator PCB	◆

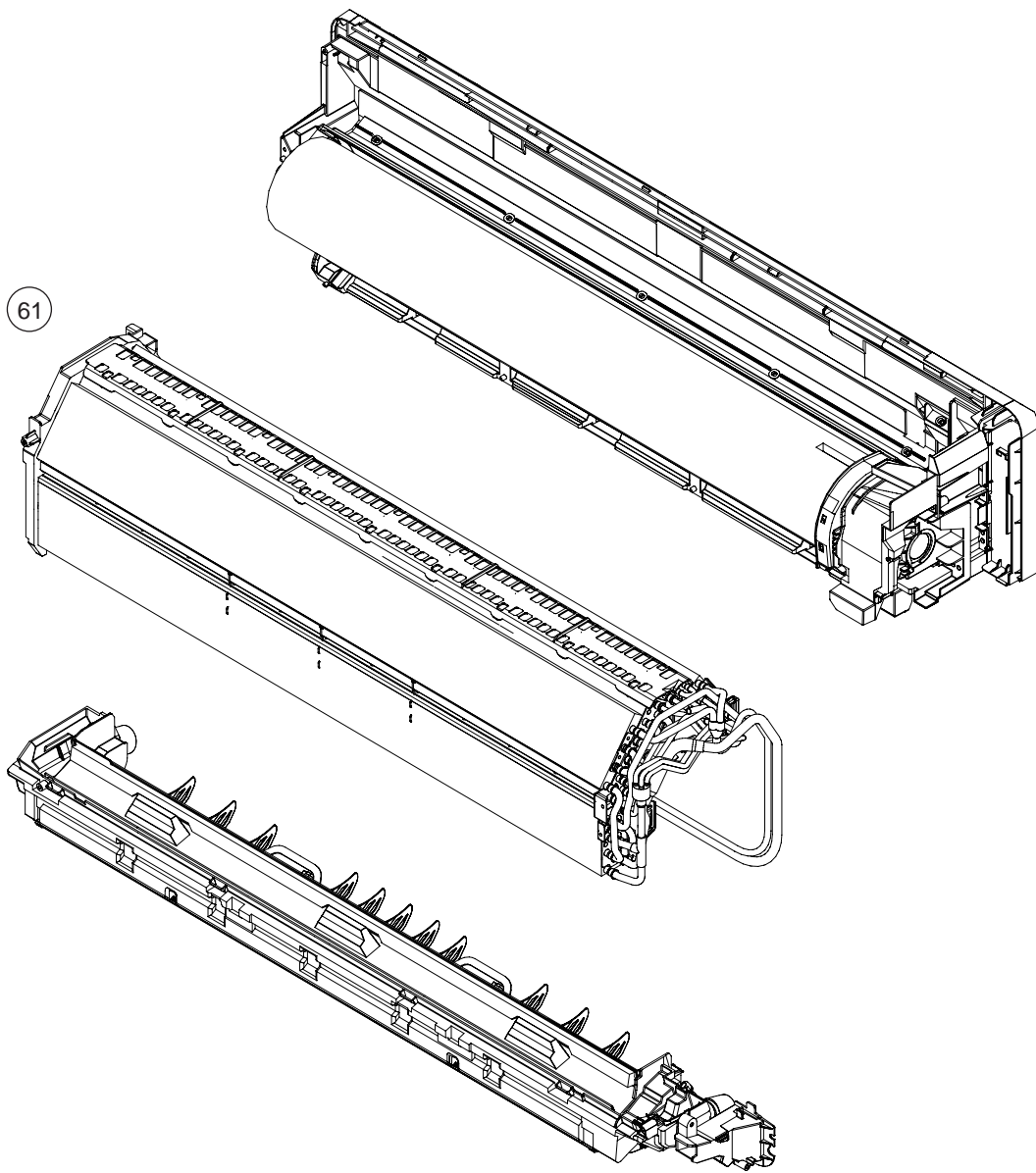

Item no.	Part no.	Part name	Service part
61	9383735011	Evaporator total assy	◆

Base total assy
 Motor cover assy
 Fan motor

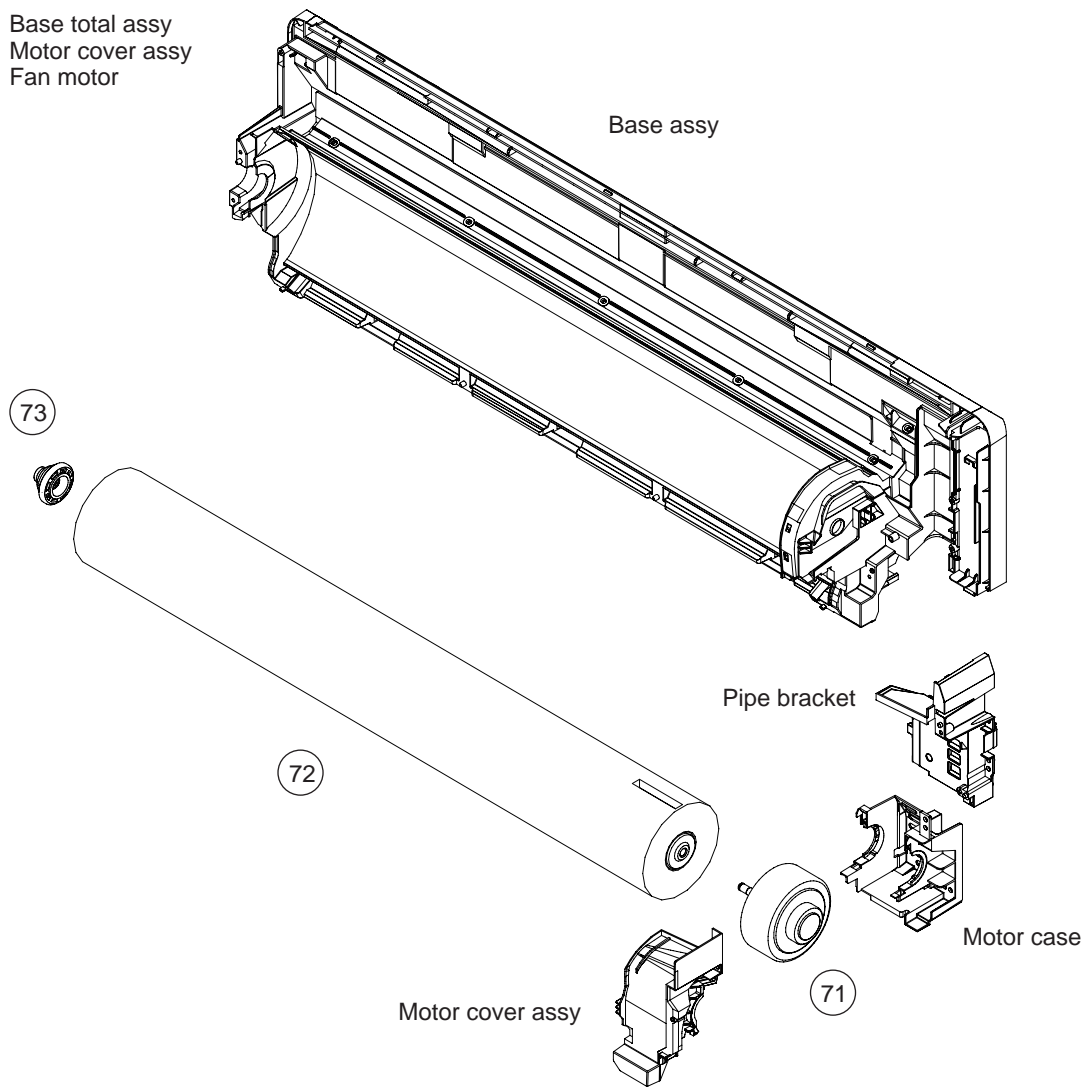

Item no.	Part no.	Part name	Service part
71	9603631000	Brushless motor	◆
72	9387055054	Crossflow fan assy	◆
73	9333628004	Bearing D assy	◆

TECHNICAL DATA
 AND PARTS LIST

TECHNICAL DATA
 AND PARTS LIST

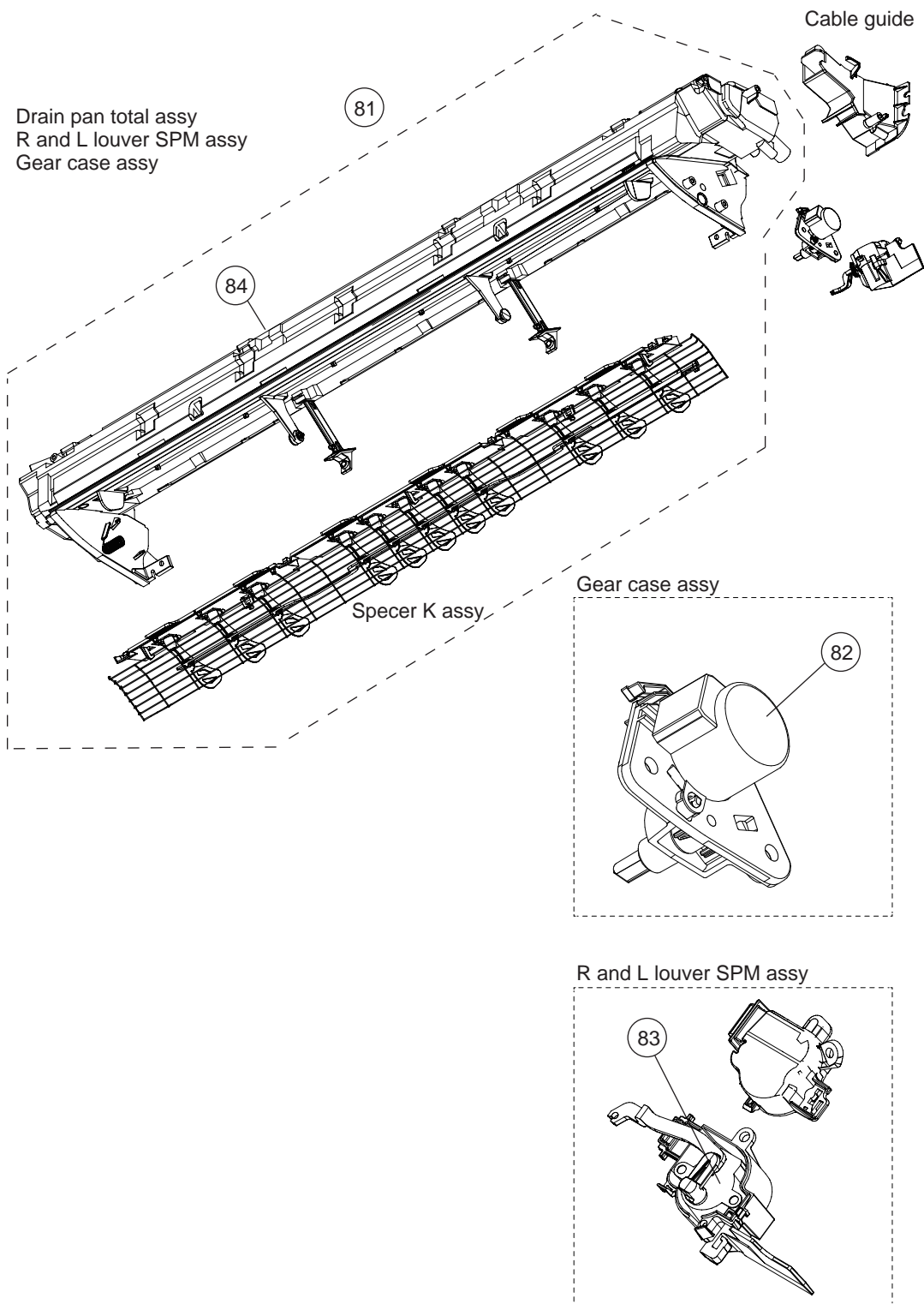

Item no.	Part no.	Part name	Service part
81	9387590142	Drain pan total assy	◆
82	9901011016	Stepping motor	◆
83	9901011023	Stepping motor	◆
84	9387590142	Drain pan assy	◆

■ Models: ASYG07KMCC, ASYG09KMCC, ASYG12KMCC, and ASYG14KMCC

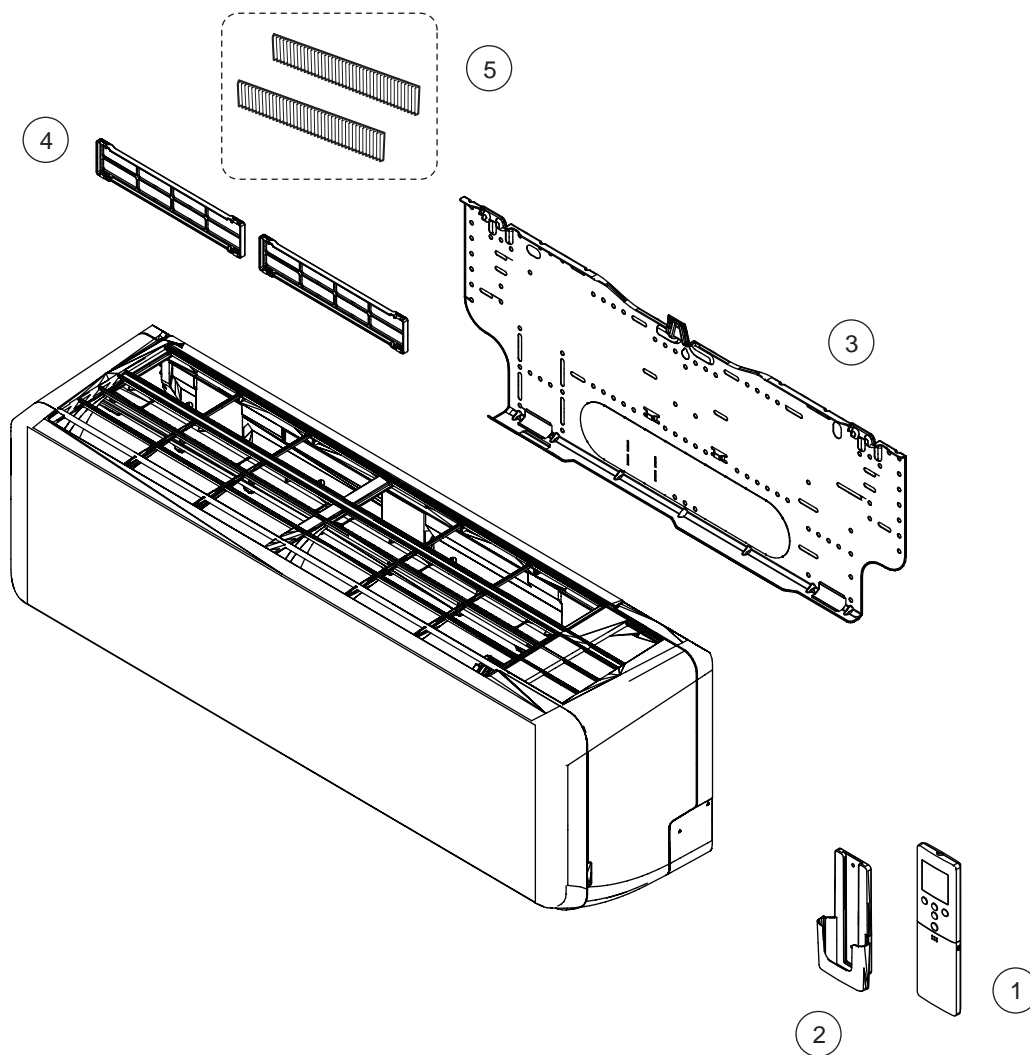

Item no.	Part no.	Part name	Service part
1	9319208008	Remote controller	◆
2	9318912005	Remote controller holder	◆
3	9387480030	Bracket panel	◆
4	9332911008	Electric filter holder	◆
5	9317250009	Air clean filter assy	◆

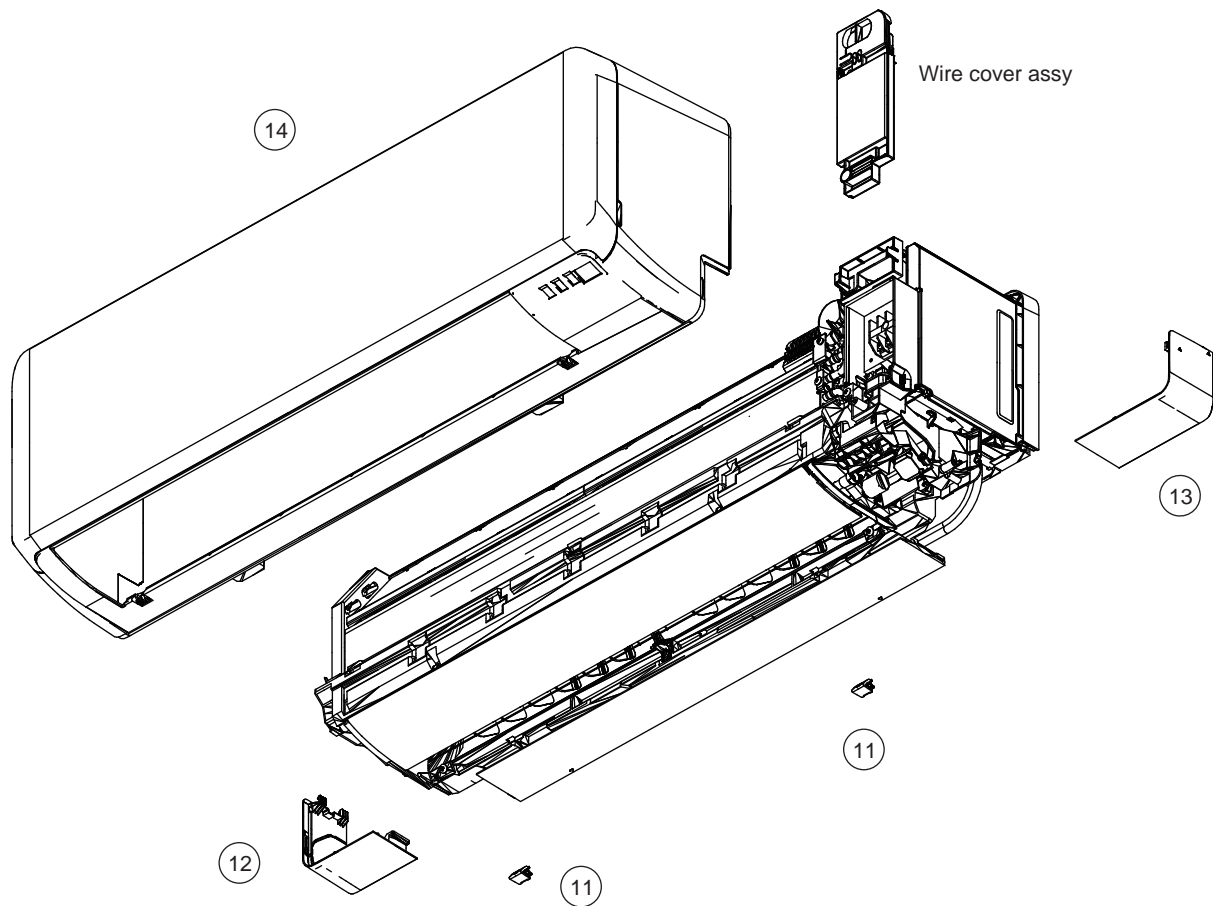

Item no.	Part no.	Part name	Service part
11	9387476002	Screw cap	◆
12	9387477009	Under cover L	◆
13	9387478006	Under cover R	◆
14	9387596410	Front panel total assy	◆

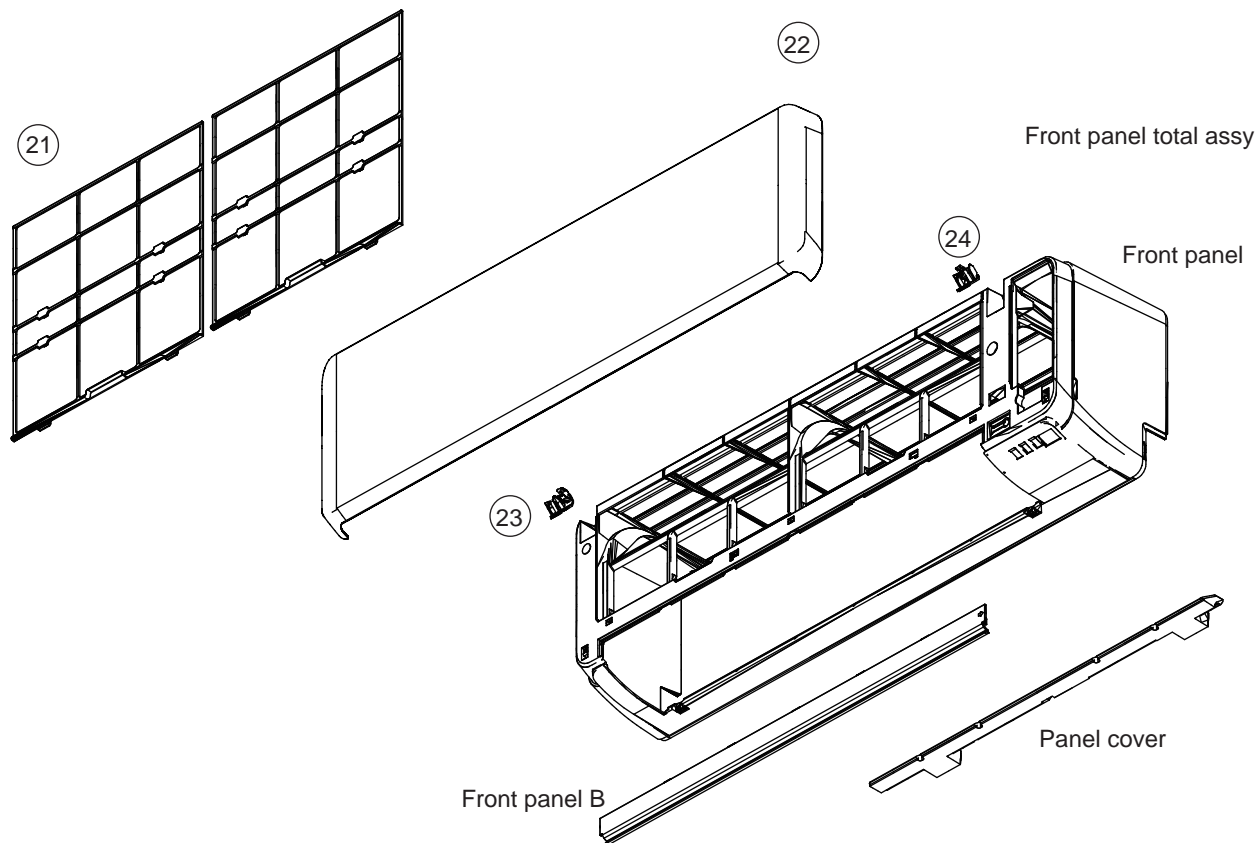

Item no.	Part no.	Part name	Service part
21	9387473018	Air filter	◆
22	9323546004	Intake grille assy	◆
23	9333719009	Grille clamber L	◆
23	9333704005	Grille clamber R	◆

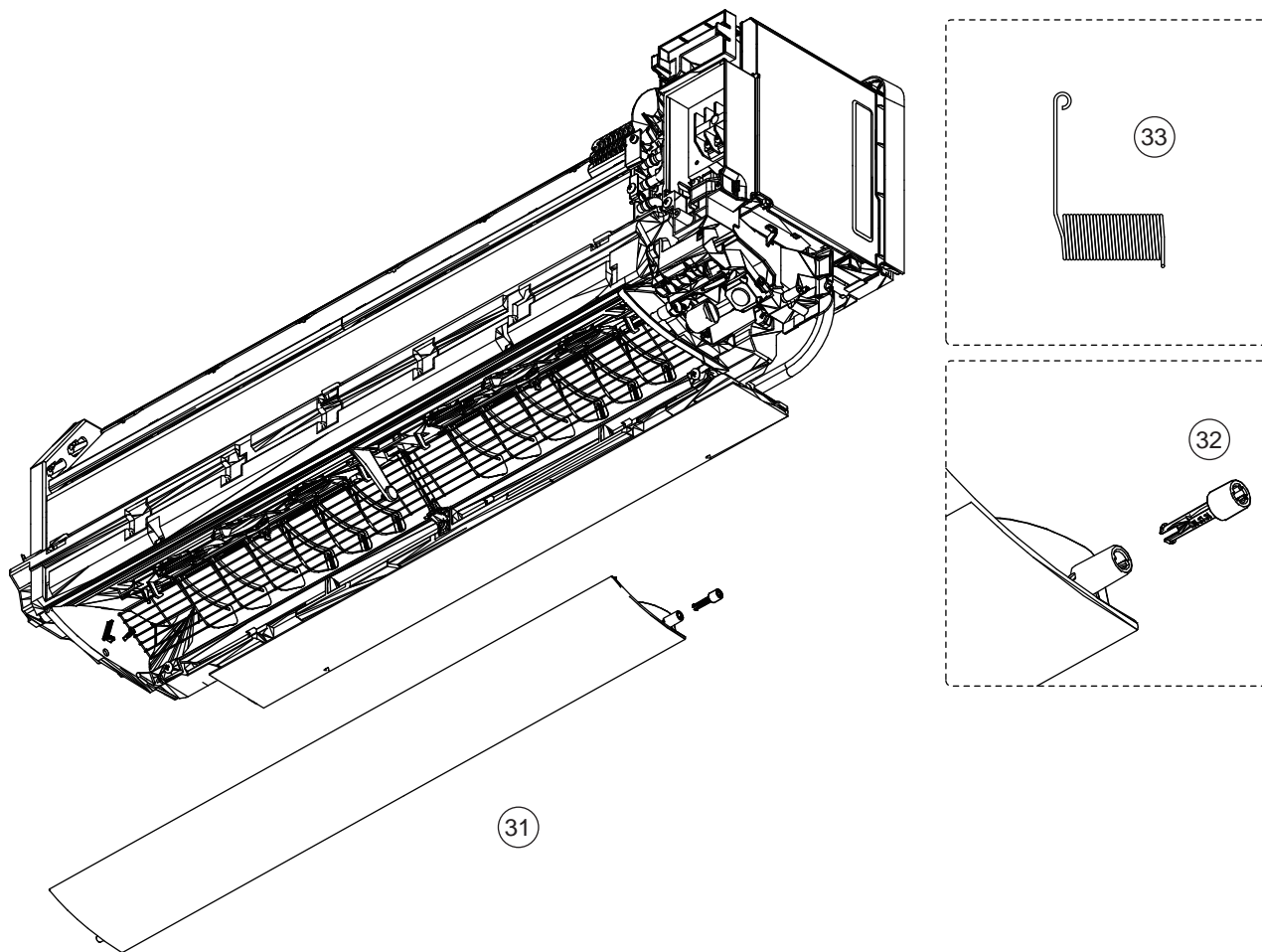

Item no.	Part no.	Part name	Service part
31	9387479041	U/D louver assy	◆
32	9332861006	Shaft cover	◆
33	9333951003	Louver spring	◆

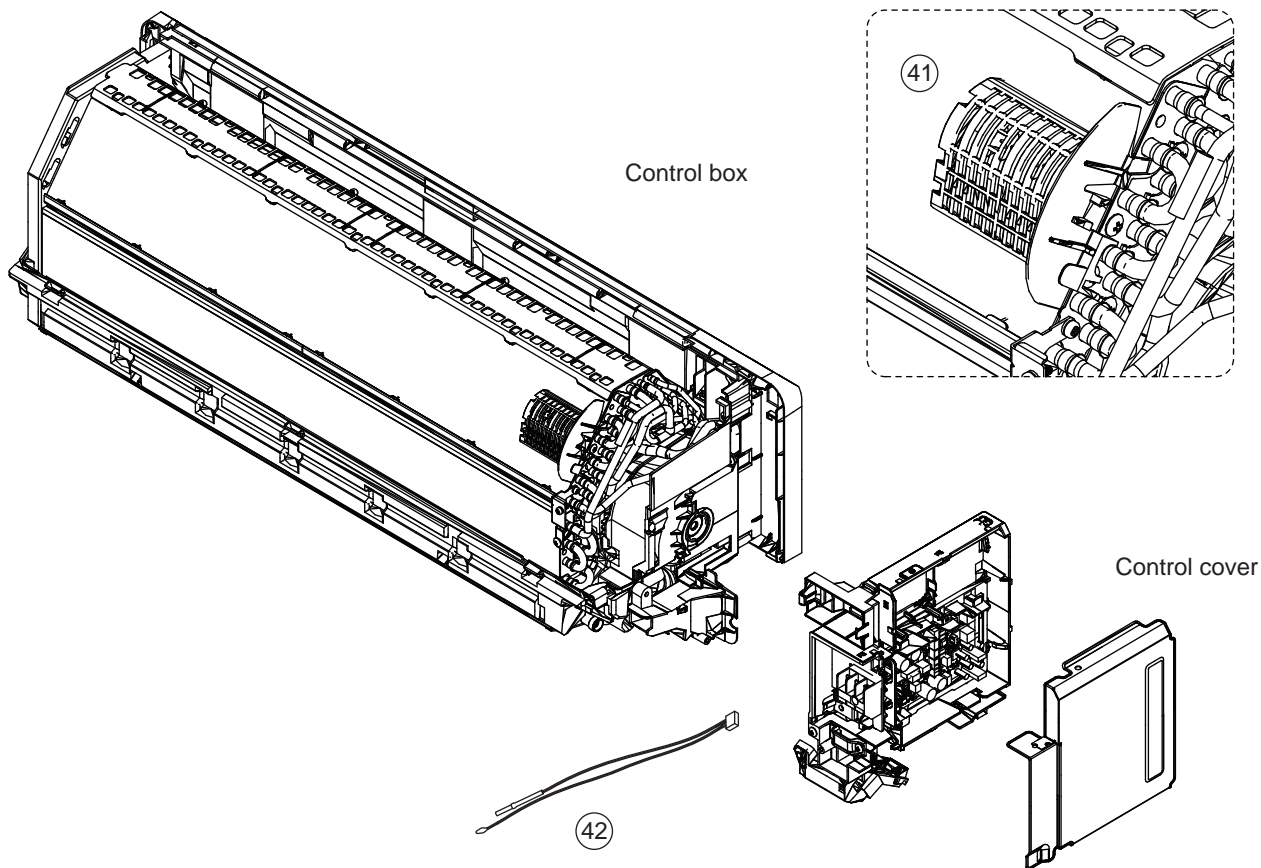

Item no.	Part no.	Part name	Service part
41	9387467017	Room thermistor holder	◆
42	9900627027	Thermistor assy	◆

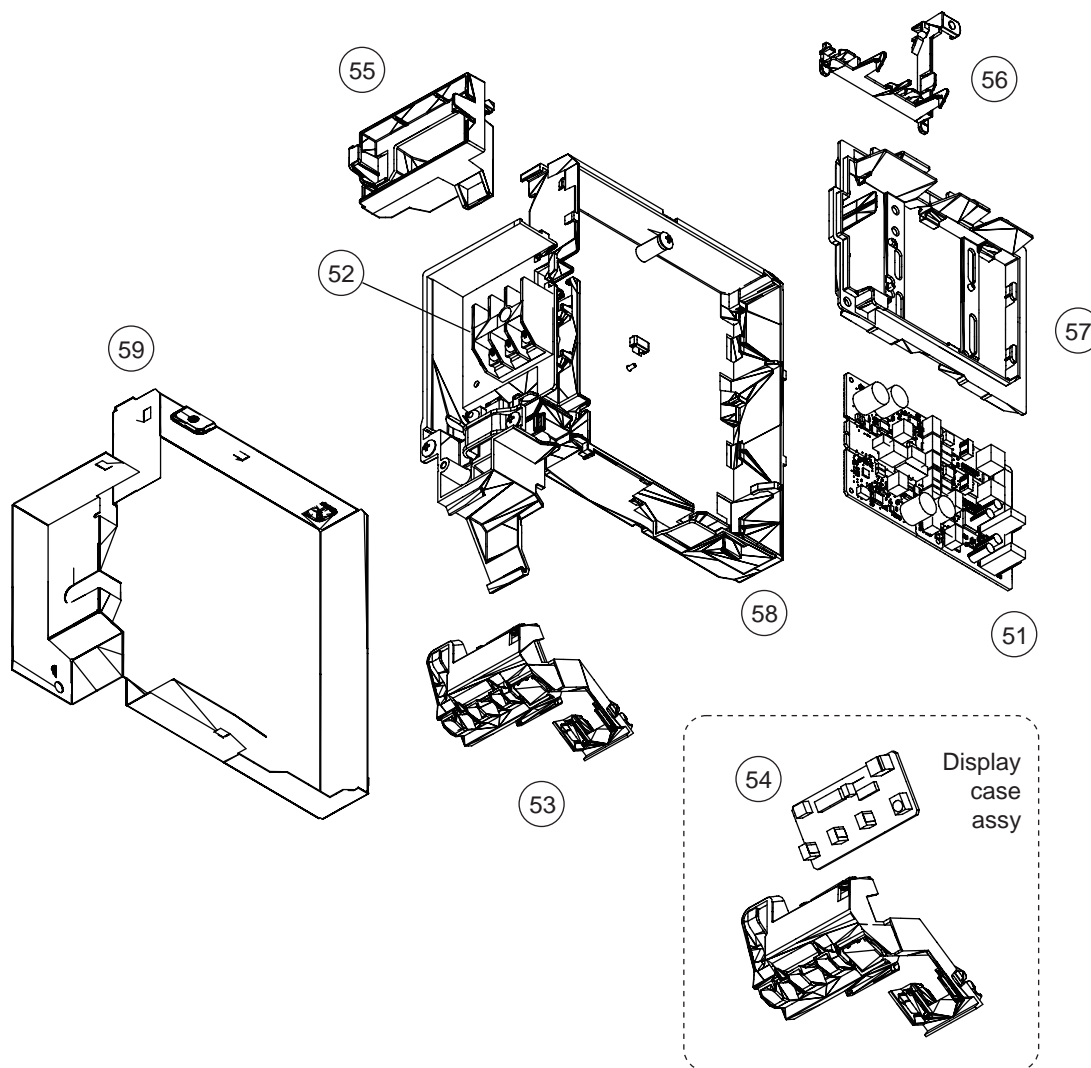

Item no.	Part no.	Part name	Service part
51	9710368448	Main PCB (For 07 model)	◆
	9710368455	Main PCB (For 09 model)	◆
	9710368462	Main PCB (For 12 model)	◆
	9710368479	Main PCB (For 14 model)	◆
52	9901013027	Terminal	◆
53	9711146069	Display assy	◆
54	9711147042	Indicator PCB	◆
55	9387485004	WLAN holder	◆
56	9387464009	PWB holder A	◆
57	9387795011	PWB holder B	◆
58	9387463026	Control box	◆
59	9323537002	Box shield	◆

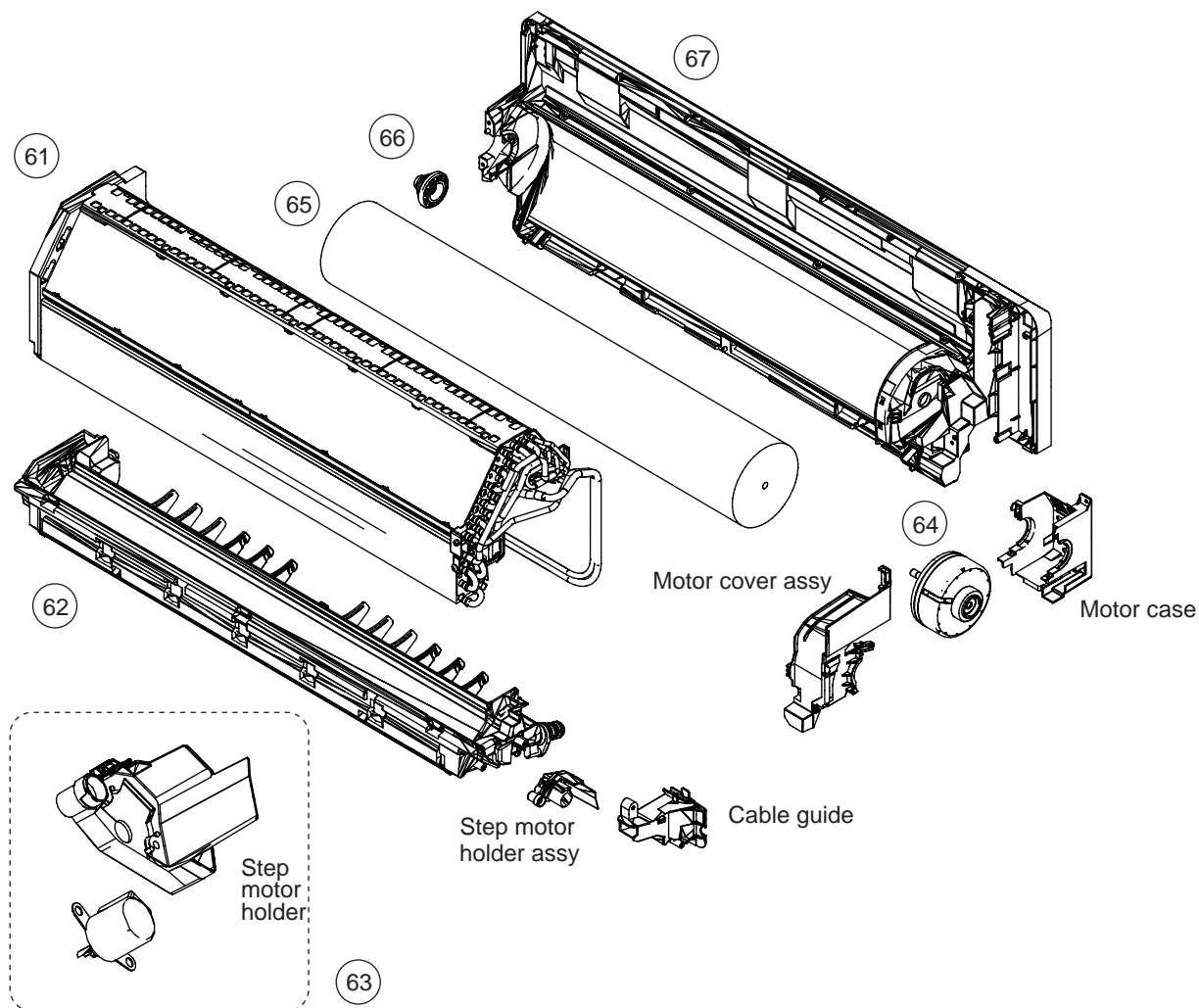

Item no.	Part no.	Part name	Service part
61	9387593211	Evaporator total assy (For 07, 09, 12 model)	◆
	9387593204	Evaporator total assy (For 14 model)	◆
62	9387590104	Drain pan total assy	◆
63	9387714036	Step motor holder assy	◆
64	9603688011	Brushless motor (For 07, 09, 12 model)	◆
	9603492014	Brushless motor (For 14 model)	◆
65	9333606033	Crossflow fan assy	◆
66	9333628004	Bearing D assy	◆
67	9387587074	Base assy	◆

■ Models: ASYG07KETA, ASYG09KETA, ASYG12KETA, ASYG14KETA, ASYG07KETA-B, ASYG09KETA-B, ASYG12KETA-B, and ASYG14KETA-B

● Exterior parts

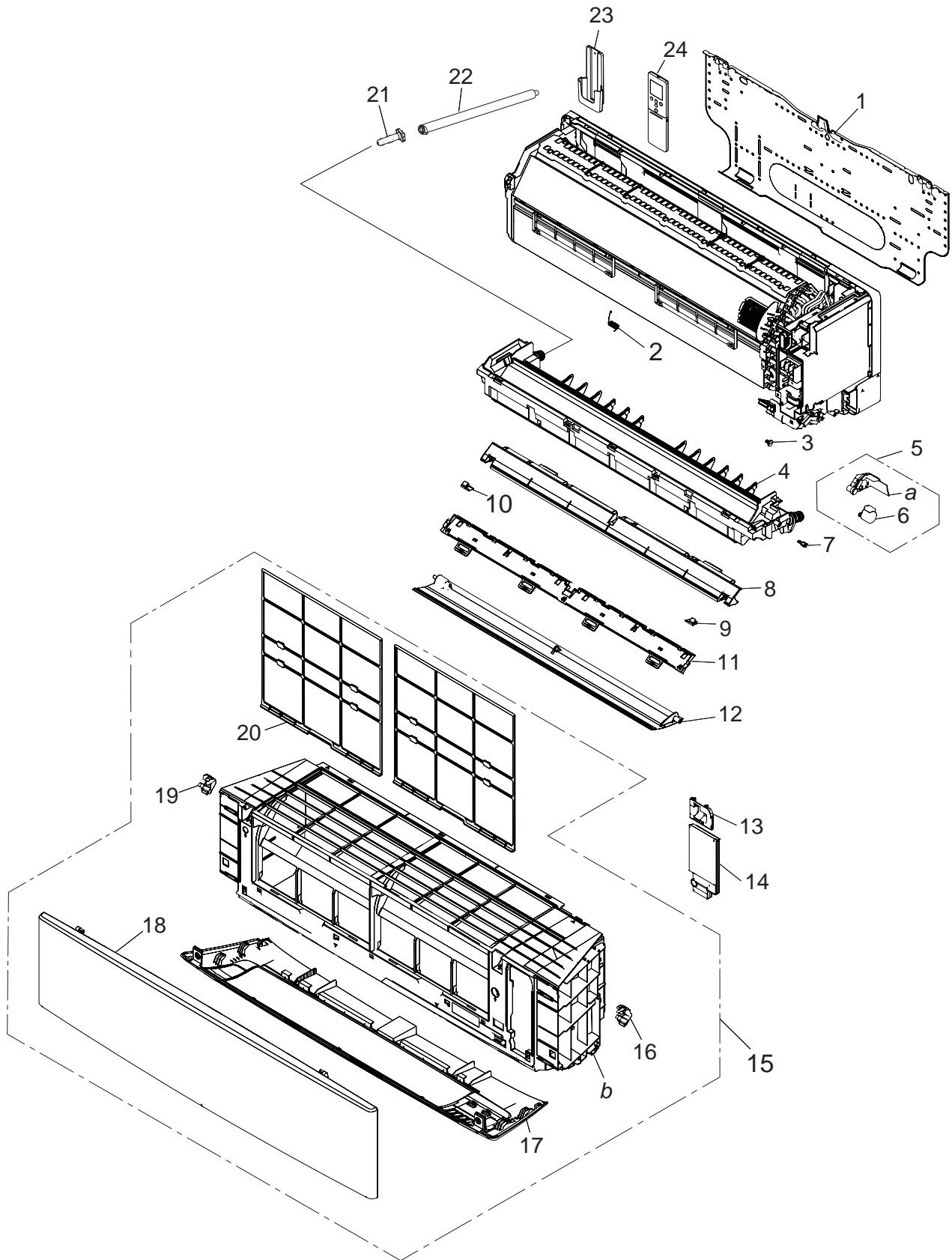

TECHNICAL DATA
AND PARTS LIST

TECHNICAL DATA
AND PARTS LIST

Item no.	Part no.	Part name	Service part
1	9387480023	Bracket panel	◆
2	9387471007	Louver spring	◆
3	9333608006	Bush	◆
4	9387590050	Drain pan total assy	◆
5	9387714036	Step motor holder assy	◆
6	9901011047	Step motor	◆
7	9332861006	Shaft cover (07-14KETA model)	◆
	9332861013	Shaft cover (07-14KETA-B model)	◆
8	9333766072	Blow panel assy (07-14KETA model)	◆
	9333766089	Blow panel assy (07-14KETA-B model)	◆
9	9384065001	Cap (screw) L (07-14KETA model)	◆
	9384065018	Cap (screw) L (07-14KETA-B model)	◆
10	9384066008	Cap (screw) R (07-14KETA model)	◆
	9384066015	Cap (screw) R (07-14KETA-B model)	◆
11	9387711028	Spacer H assy	◆
12	9387479003	U/D louver assy (07-14KETA model)	◆
	9387479034	U/D louver assy (07-14KETA-B model)	◆
13	9383613036	Wire cover B (07-14KETA model)	◆
	9383613043	Wire cover B (07-14KETA-B model)	◆
14	9387597035	Wire cover assy (07-14KETA model)	◆
	9387597073	Wire cover assy (07-14KETA-B model)	◆
15	9387596304	Front panel total assy (07-14KETA model)	◆
	9387596311	Front panel total assy (07-14KETA-B model)	◆
16	9333704005	Grille clamper R	◆
17	9384140005	Under cover assy (07-14KETA model)	◆
	9384140036	Under cover assy (07-14KETA-B model)	◆
18	9387756159	Intake grille assy (07-14KETA model)	◆
	9387756166	Intake grille assy (07-14KETA-B model)	◆
19	9333719009	Grille clamper L	◆
20	9387473018	Air filter	◆
21	9316177017	Drain cap	◆
22	9316904002	Drain hose assy	◆
23	9318912005	Remote controller holder	◆
24	9383712036	Remote controller	◆
<i>a</i>	—	Step motor holder	—
<i>b</i>	—	Front panel	—

Item no.	Part no.	Part name	Service part
50	9387587012	Base assy (07-14KETA model)	◆
	9387587050	Base assy (07-14KETA-B model)	◆
51	9383765032	WLAN adapter holder assy	◆
52	9711141590	Main PCB (For 07 model)	◆
	9711141606	Main PCB (For 09 model)	◆
	9711141613	Main PCB (For 12 model)	◆
	9711141620	Main PCB (For 14 model)	◆
53	9711382009	Display assy	◆
54	9711358004	PWB ASSY	◆
55	9900369057	Terminal	◆
56	9603768003	Brushless motor (For 07-12 model)	◆
	9603631017	Brushless motor (For 14 model)	◆
57	9387589030	Motor case assy	◆
58	9317250009	Air clean filter assy	◆
59	9332911008	Electric filter holder	◆
60	9387593143	Evaporator total assy (For 07-12 model)	◆
	9387593150	Evaporator total assy (For 14 model)	◆
61	9900627041	Thermistor assy	◆
62	9387467000	Room thermistor holder	◆
63	9333628004	Bearing D assy	◆
64	9387055047	Crossflow fan assy	◆
a	-	Box shield	—
b	-	Control box	—
c	-	PCB holder A	—
d	-	Motion sensor	—
e	-	Front panel cover B assy	—
f	-	Display case assy	—
g	-	Control cover	—
h	-	Motor case	—
i	-	Motor cover	—

3-5. Ceiling type

■ Model: ABYG18KRTA

● Chassis

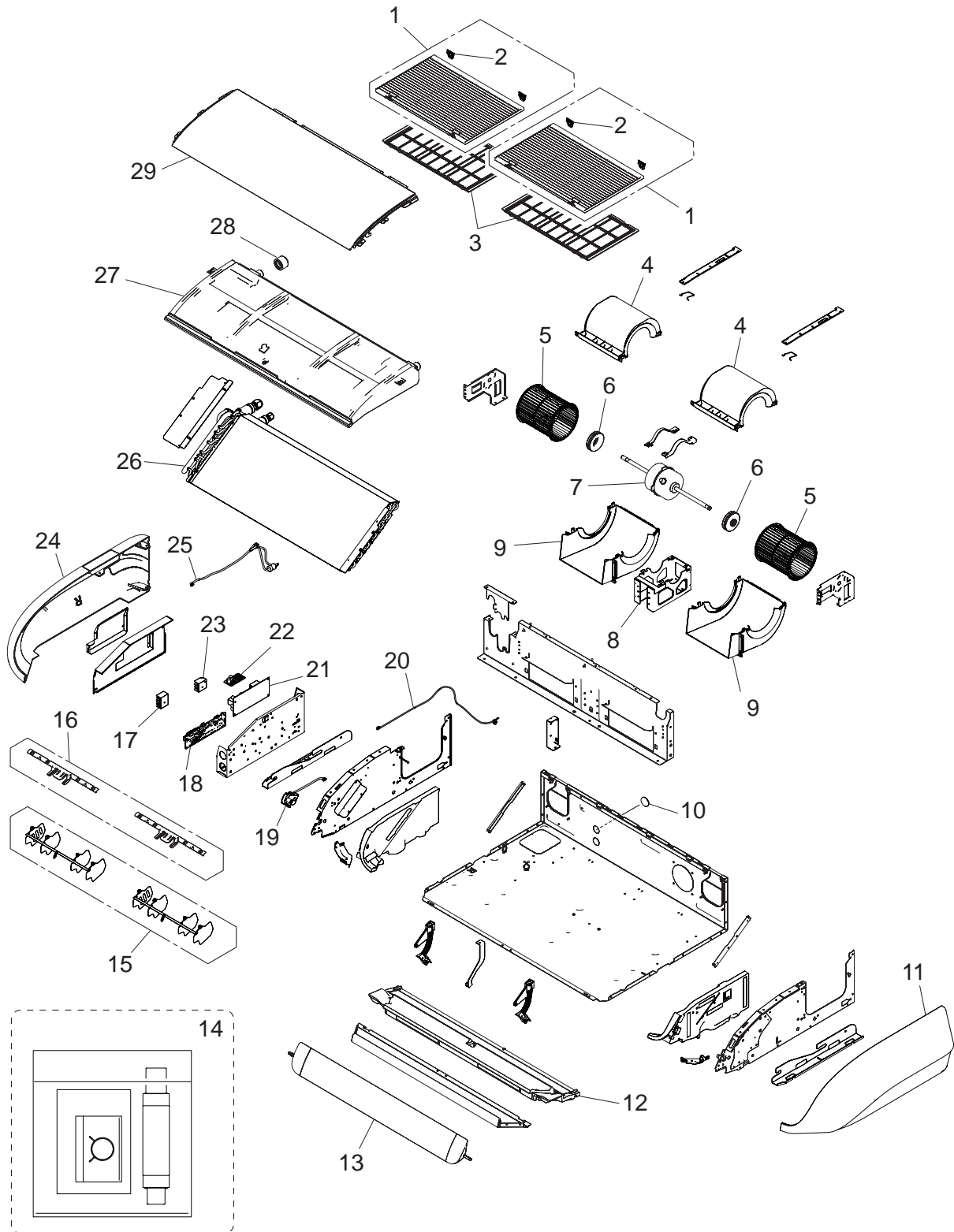

TECHNICAL DATA
AND PARTS LIST

TECHNICAL DATA
AND PARTS LIST

Item no.	Part no.	Part name	Service part
1	9384321015	Intake grille B sub assy	◆
2	9383344008	Grille hinge (2 pcs.)	◆
3	9383342011	Air filter B	◆
4	9384307002	Casing U assy	◆
5	9384110015	Sirocco fan assy	◆
6	9383443008	Rubber (Vibration proof)	◆
7	9603817008	Brushless DC motor	◆
8	9384236005	Motor mount assy	◆
9	9384311009	Casing B assy	◆
10	9352173011	Cap (Power)	◆
11	9383406003	Side panel L	◆
12	9384308023	Top panel cover assy (2-fan)	◆
13	9384144027	Flap assy (2-fan)	◆
14	9384324009	Hose sub assy	◆
15	9383384004	L and R louver	◆
16	9383385001	Base (Louver)	◆
17	9900896027	Terminal (5P)	◆
18	9710995972	Main PCB	◆
19	9384312006	Box (Gear) sub assy	◆
20	9900960049	Thermistor (Room)	◆
21	9710661006	Power supply PCB	◆
22	9710019005	2-way remote PCB	◆
23	9306489045	Terminal (3P)	◆
24	9384320001	Side panel R sub assy	◆
25	9900892029	Thermistor (Pipe)	◆
26	9384287021	Evaporator total assy	◆
27	9384364029	Drain pan total assy (2-fan)	◆
28	9358746004	Drain cap	◆
29	9384241023	Front panel (2-fan) assy	◆

3-6. Floor type

■ Models: AGYG09KVCA, AGYG12KVCA, and AGYG14KVCA

● Exterior parts and chassis

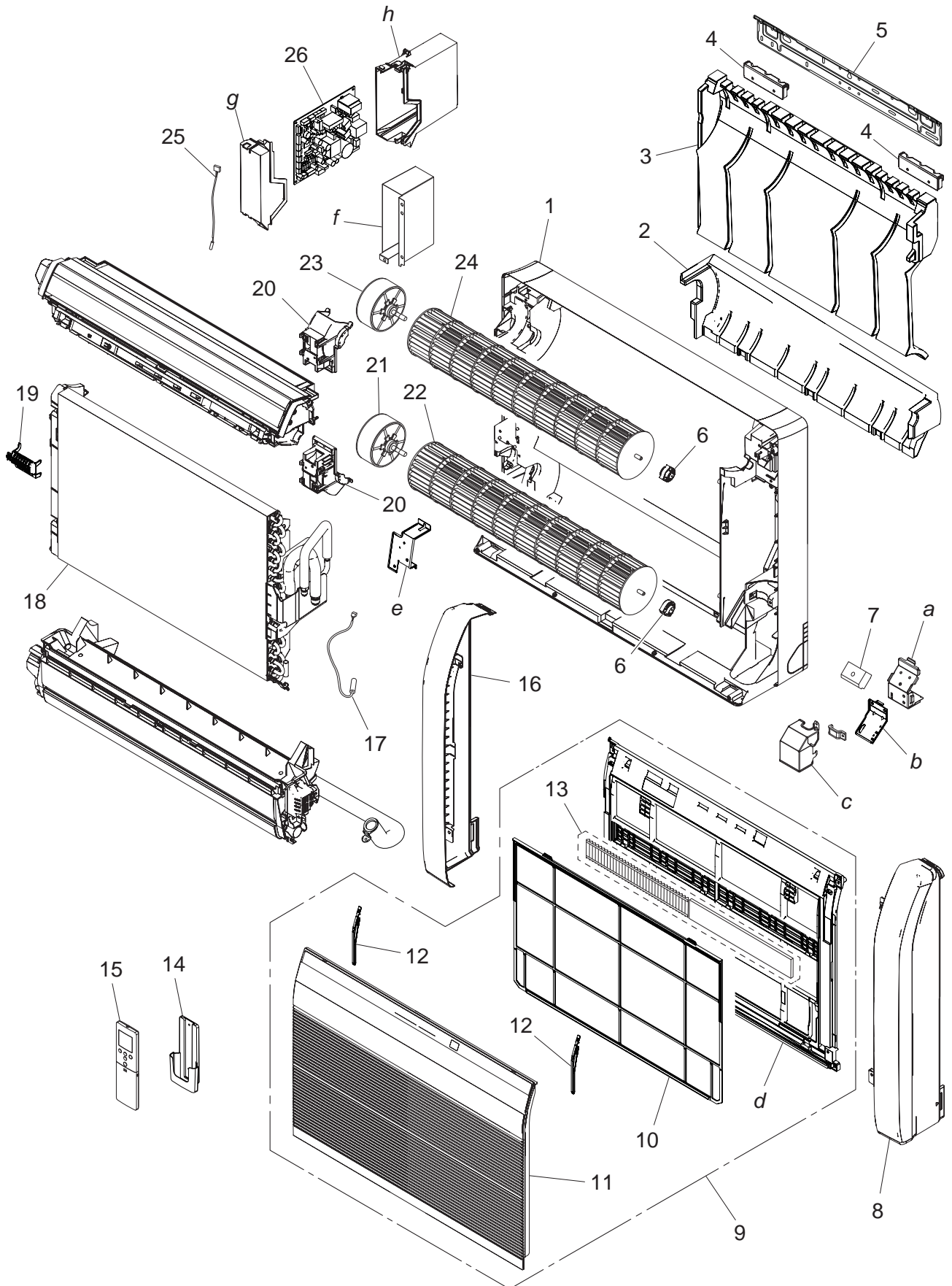

TECHNICAL DATA
AND PARTS LIST

TECHNICAL DATA
AND PARTS LIST

Item no.	Part no.	Part name	Service part
1	9316193024	Base	◆
2	9316197015	Base cover A	◆
3	9316373013	Base cover B	◆
4	9316405011	Base bracket	◆
5	9316272019	Bracket panel	◆
6	9306628024	Bearing C assy	◆
7	9900720087	Terminal (3P)	◆
8	9316186019	Front panel R	◆
9	9316415164	Front panel total assy	◆
10	9316189027	Air filter	◆
11	9316418059	Intake grille assy	◆
12	9316458017	Rope assy	◆
13	9316474017	Air clean filter assy	◆
14	9318912005	Remote controller holder	◆
15	9332438864	Remote controller	◆
16	9316187016	Front panel L	◆
17	9900991005	Pipe thermistor	◆
18	9316091269	Evaporator total assy	◆
19	9316192027	Thermistor holder	◆
20	9316195011	Motor holder	◆
21	9602851003	Fan motor (MFD-14SXN)	◆
22	9316309012	Crossflow fan B assy	◆
23	9602850006	Fan motor (MFD-14TXN)	◆
24	9312004034	Crossflow fan assy	◆
25	9900975067	Room thermistor	◆
26	9711694065	Main PCB (09 model)	◆
	9711694072	Main PCB (12 model)	◆
	9711694089	Main PCB (14 model)	◆
<i>a</i>	—	Terminal bracket	—
<i>b</i>	—	Cable bracket	—
<i>c</i>	—	Terminal cover	—
<i>d</i>	—	Front panel	—
<i>e</i>	—	Terminal bracket (COM)	—
<i>f</i>	—	Control box shield	—
<i>g</i>	—	Control box cover	—
<i>h</i>	—	Control box	—

● Casing

TECHNICAL DATA
AND PARTS LIST

TECHNICAL DATA
AND PARTS LIST

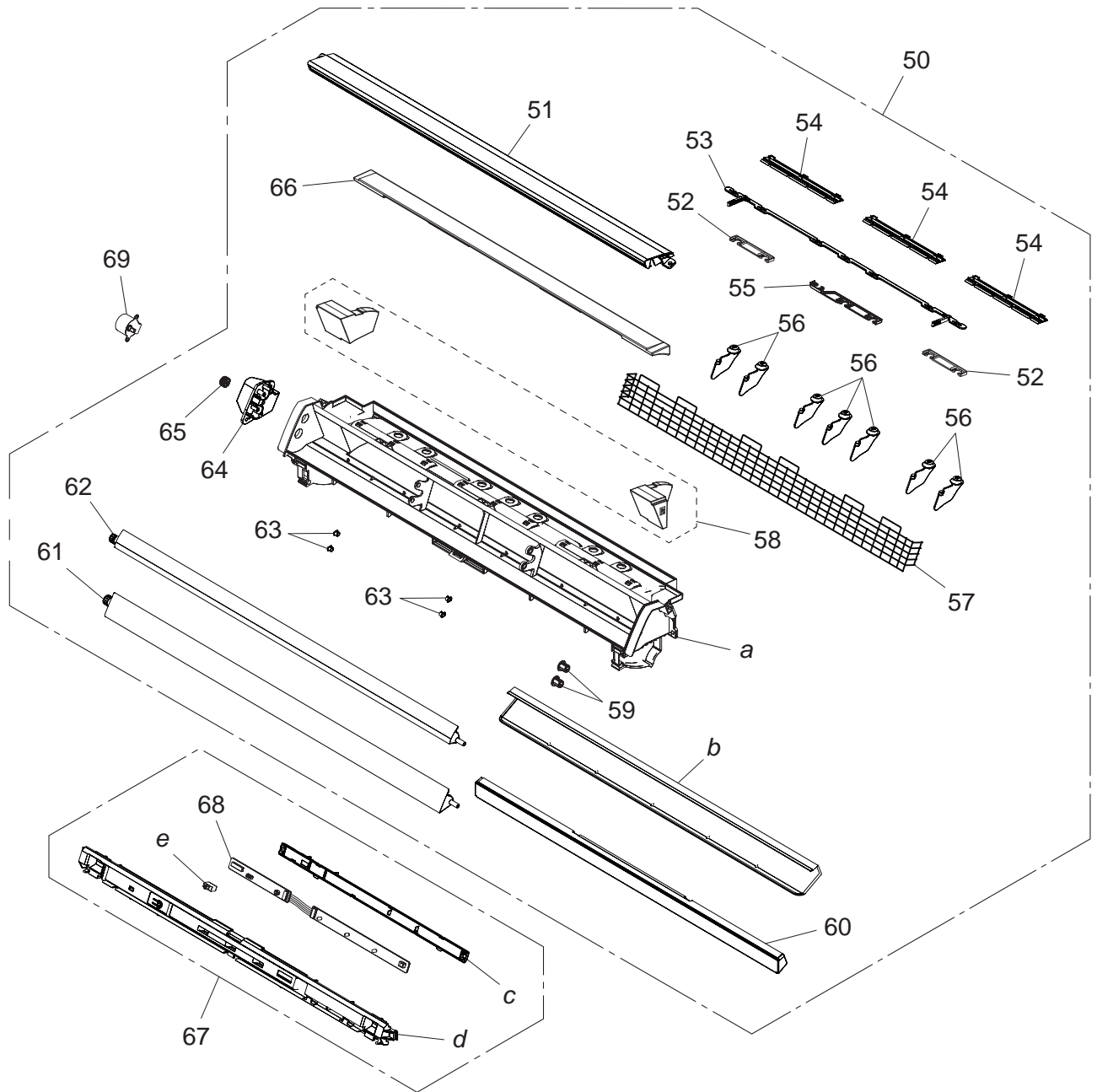

Item no.	Part no.	Part name	Service part
50	9316411012	Casing assy	◆
51	9316207011	Top cover	◆
52	9315281012	Spacer C	◆
53	9316209015	Joint U	◆
54	9316210011	Guard holder	◆
55	9315282019	Spacer D	◆
56	9316208018	L and R louver U	◆
57	9316211018	Fan guard	◆
58	9316310018	Casing cover L and R	◆
59	9303529010	Bushing B	◆
60	9316308015	Casing cover F	◆
61	9316206014	Louver Z	◆
62	9316205017	Louver U	◆
63	9303529010	Bushing A	◆
64	9316213012	Gear case	◆
65	9309994003	Gear A	◆
66	9316273016	Casing cover B	◆
67	9711714008	Display assy	◆
68	9711696007	Indicator PCB	◆
—	9707580020	Wire with connector (P1002 on Indicator PCB—P360 on Main PCB)	◆
—	9707581010	Wire with connector (White) (P1001 on Indicator PCB—P1000 on Indicator PCB)	◆
69	9900384043	Step motor (Up/Down)	◆
<i>a</i>	—	Casing	—
<i>b</i>	—	Casing reinforcement	—
<i>c</i>	—	Display cover	—
<i>d</i>	—	Display case	—
<i>e</i>	—	Switch cover	—

● Drain pan

TECHNICAL DATA
AND PARTS LIST

TECHNICAL DATA
AND PARTS LIST

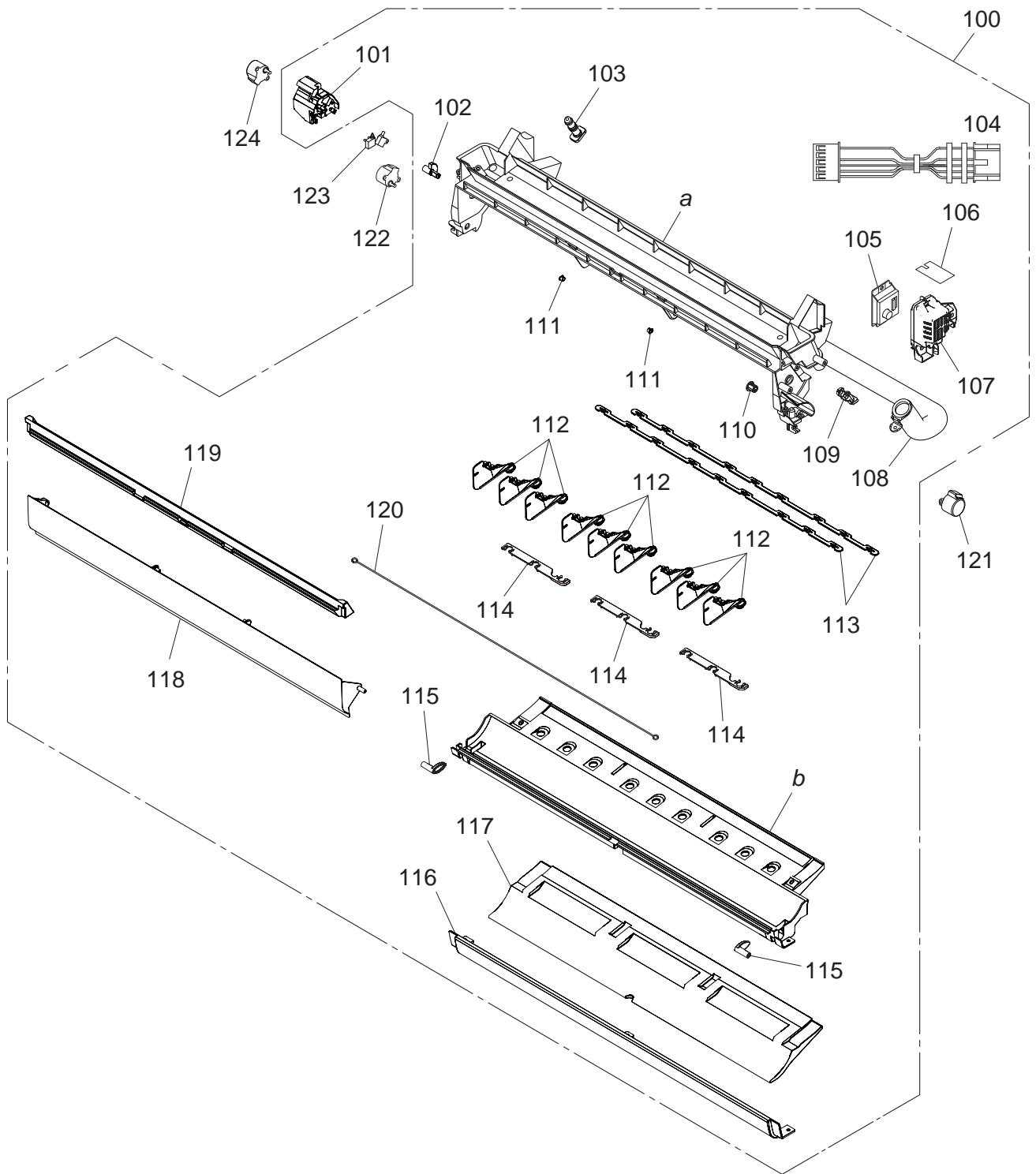

Item no.	Part no.	Part name	Service part
100	9316412057	Drain pan assy	◆
101	9316217010	Limit switch cover	◆
102	9316218017	Key top	◆
103	9316177017	Drain cap	◆
104	9711683007	Wire with connector (Refrigerant leak detect sensor—P410 on Main PCB)	◆
105	9901089008	Refrigerant leak detect sensor	◆
106	9384838001	Sensor cover seal	◆
107	9384709004	Sensor cover	◆
108	9314147029	Drain hose assy	◆
109	9316384019	Drain hose holder	◆
110	9312156016	Bushing B	◆
111	9303529010	Bushing A	◆
112	9316334014	L and R louver Z	◆
113	9316335011	Joint Z	◆
114	9315282019	Spacer D	◆
115	9316219014	Stopper	◆
116	9316374010	Lower cover	◆
117	9316386013	Drain pan cover B	◆
118	9316216013	Damper	◆
119	9316274013	Drain pan cover F	◆
120	9316918009	Fan guard Z	◆
121	9900384074	Step motor (Damper lock R)	◆
122	9900384067	Step motor (Damper lock L)	◆
123	9900424015	Micro switch (Limit)	◆
124	9900384050	Step motor (Damper)	◆
<i>a</i>	—	Drain pan U	—
<i>b</i>	—	Drain pan Z	—

4. Outdoor unit parts list

4-1. Models: AOYG18KBTA3 and AOYG24KBTA3

■ Exterior parts and Chassis

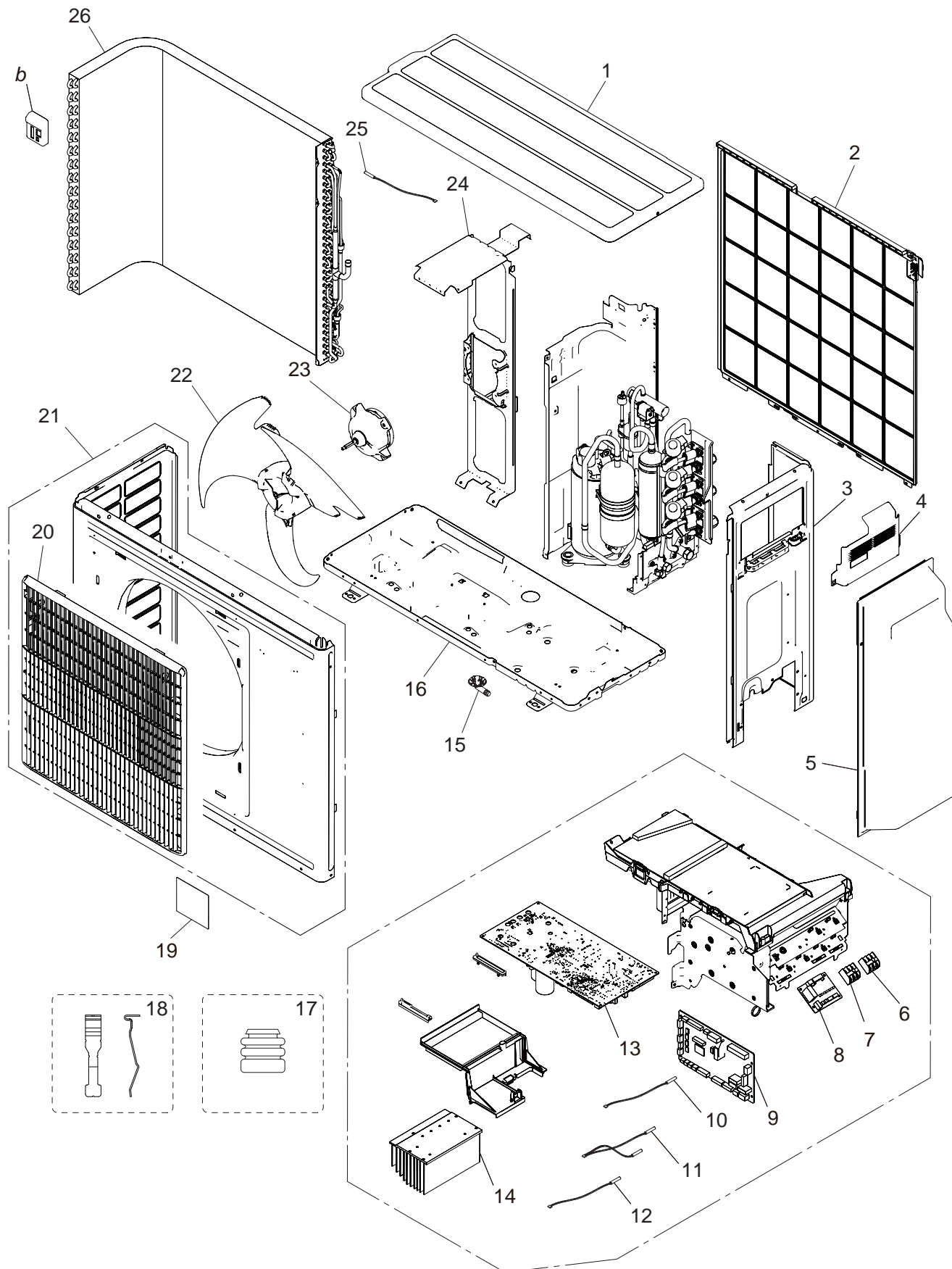

TECHNICAL DATA AND PARTS LIST

TECHNICAL DATA AND PARTS LIST

Item no.	Part no.	Part name	Service part
1	9322556073	Top panel assy	◆
2	9322811042	Protective net	◆
3	9322552266	Cabinet right assy	◆
4	9322554031	Terminal cover assy	◆
5	9322570079	Switch cover assy	◆
6	9900369064	Terminal (Power)	◆
7	9900369071	Terminal (Inner)	◆
8	9711609007	Indicator PCB	◆
9	9711674005	Main PCB (For 18 model)	◆
	9711674012	Main PCB (For 24 model)	◆
10	9900565008	Thermistor assy (Outdoor temp.) (For 18 model)	◆
	9900565060	Thermistor assy (Outdoor temp.) (For 24 model)	◆
11	9900727048	Thermistor assy (For 18 model)	◆
	9900727116	Thermistor assy (For 24 model)	◆
12	9900985035	Compressor thermistor (For 18 model)	◆
	9900985011	Compressor thermistor (For 24 model)	◆
13	9709685778	Inverter PCB	◆
14	9322421043	Heat sink	◆
15	9322144003	Drain pipe	◆
16	9322322043	Base assy	◆
17	9322386007	Cushion rubber	◆
18	9810028006	Thermistor stopper	◆
19	9319151007	Emblem	◆
20	9322149008	Blow grille	◆
21	9322555267	Front panel assy	◆
22	9322150004	Propeller fan	◆
23	9603601003	Brushless motor	◆
24	9322553034	Motor bracket assy	◆
25	9900041014	Thermistor (Heat exchanger)	◆
26	9317089791	Condenser total assy	◆
<i>a</i>	—	Inverter assy	—
<i>b</i>	—	Hair pin cushion	—

Compressor

TECHNICAL DATA
AND PARTS LIST

TECHNICAL DATA
AND PARTS LIST

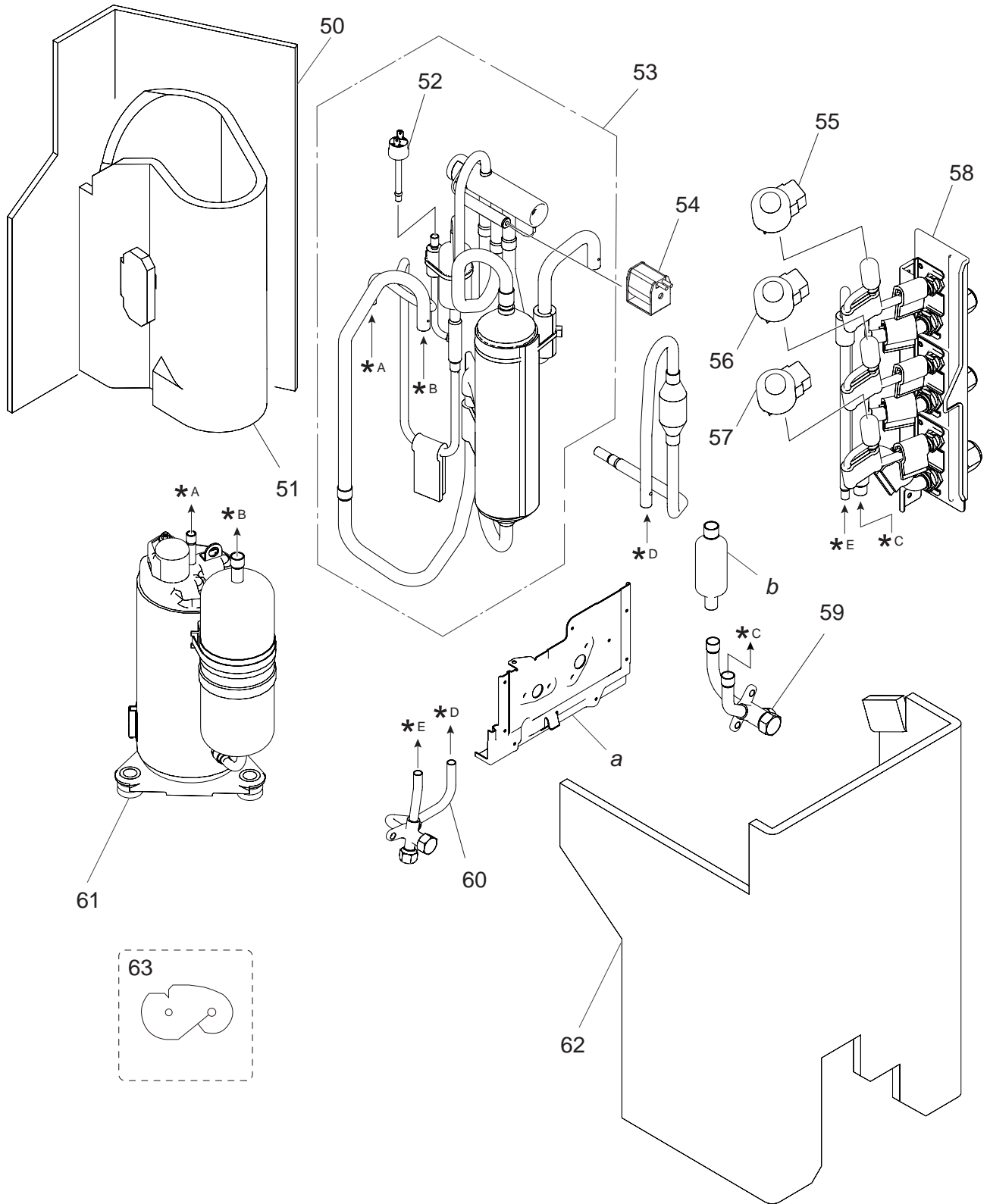





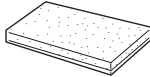
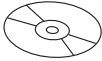

Item no.	Part no.	Part name	Service part
50	9384904003	S-insulator K	◆
51	9384901002	S-insulator B	◆
52	9900186029	Pressure switch	◆
53	9384894007	4-way valve assy	◆
54	9970194016	Solenoid	◆
55	9970186073	Expansion valve coil C (L=1160)	◆
56	9970187049	Expansion valve coil B (L=1040)	◆
57	9970186066	Expansion valve coil A (L=920)	◆
58	9384866011	Valve unit sub assy (For 18 model)	◆
	9384866004	Valve unit sub assy (For 24 model)	◆
59	9322477040	3-way valve assy (Ø12.70)	◆
60	9381055029	3-way valve assy (Ø9.52)	◆
61	9810520005	Compressor	◆
62	9384902009	S-insulator F	◆
63	9384903006	S-insulator H	◆
—	9901025020	Thermistor (Valve temperature) A, B	◆
—	9901093012	Thermistor (Valve temperature) C	◆
—	9711839008	Wire with connector (P131 on Main PCB—P133 on Indicator PCB)	◆
—	9711840004	Wire with connector (P130 on Main PCB—P132 on Indicator PCB)	◆
—	9711203021	Wire with connector (P660 on Main PCB—P662 on Inverter PCB)	◆
—	9711841001	Wire with connector (P100 on Main PCB—P101 on Inverter PCB)	◆
—	9710542015	Wire assy (P20 on Inverter PCB—Pressure switch)	◆
<i>a</i>	—	Valve bracket	—
<i>b</i>	—	Muffler	—

5. Accessories

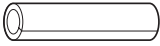
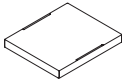
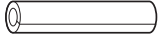



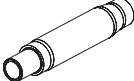

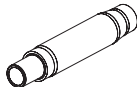
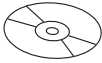

5-1. Compact cassette type

■ Models: AUXG07KVLA, AUXG09KVLA, AUXG12KVLA, AUXG14KVLA, and AUXG18KVLA



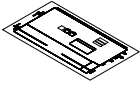

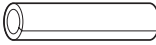

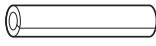
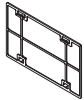
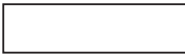

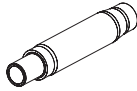
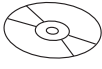

Part name	Exterior	Q'ty	Part name	Exterior	Q'ty
Operating manual		1	Drain hose insulation		1
Operating manual (CD-ROM)		1	Hose band		1
Installation manual		1	Coupler heat insulation (large)		1
Template (Carton top)		1	Coupler heat insulation (small)		1
M10 nut A (with flange)		4	Cable tie		2
M10 nut B (with spring lock washer)		4	Wire crammer		1
Drain hose		1			

5-2. Mini duct type

■ Models: ARXG07KSLAP, ARXG09KSLAP, ARXG12KSLAP, and ARXG14KSLAP

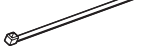
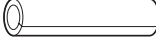

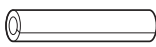









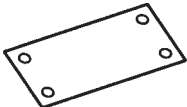
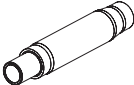

Part name	Exterior	Q'ty	Part name	Exterior	Q'ty
Operating manual		1	Drain hose		1
Operating manual (CD-ROM)		1	Hose band		1
Installation manual		1	Drain hose insulation B		1
Installation template (Carton top)		1	Washer		8
Cable tie (large)		4	Coupler heat insulation (large)		1
Cable tie (medium)		3	Coupler heat insulation (small)		1
Filter (small)		2	Insulation (For electrical wiring)		2

■ Model: ARXG18KSLAP

Part name	Exterior	Q'ty	Part name	Exterior	Q'ty
Operating manual		1	Drain hose		1
Operating manual (CD-ROM)		1	Hose band		1
Installation manual		1	Drain hose insulation B		1
Installation template (Carton top)		1	Washer		8
Cable tie (large)		4	Coupler heat insulation (large)		1
Cable tie (medium)		3	Coupler heat insulation (small)		1
Filter (large)		2	Insulation (For electrical wiring)		2









5-3. Slim duct type

■ Models: ARXG07KLLAP, ARXG09KLLAP, ARXG12KLLAP, ARXG14KLLAP, and ARXG18KLLAP





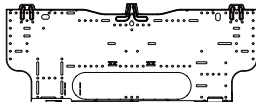
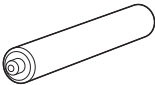

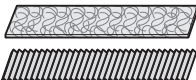

Part name	Exterior	Q'ty	Part name	Exterior	Q'ty
Operating manual		1	Cable tie (Large)		4
Installation manual		1	Cable tie (Small)		3
Installation template		1	Drain hose		1
Washer		8	Hose band		1
Coupler heat insulation (Large)		1	Drain hose insulation B		1
Coupler heat insulation (Small)		1	Remote controller		1
Filter (Small) (For 9/12 models)		2	Remote controller cable		1
Filter (Large) (For 18 models)		2	Tapping screw		2

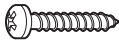
5-4. Wall mounted type







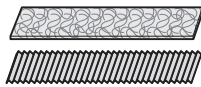
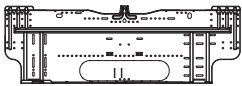

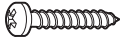

■ Models: ASYG07-14KGTB and ASYG07-14KMCC

Part name	Exterior	Q'ty	Part name	Exterior	Q'ty
Operating manual		1	Cloth tape		1
Operating manual (CD-ROM)		1	Tapping screw (large)		5
Installation manual		1	Tapping screw (small)		2
Remote controller		1	Wall hook bracket		1
Battery		2	Filter holder		2
Remote controller holder		1	Air cleaning filters		1

■ Model: ASYG18KMTB

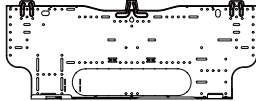



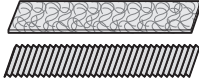
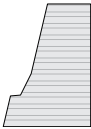





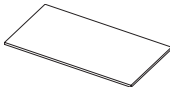
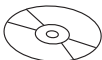
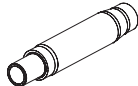

Part name	Exterior	Q'ty	Part name	Exterior	Q'ty
Operating manual		1	Tapping screw (large)		5
Installation manual		1	Tapping screw (small)		2
Remote controller		1	Battery		2
Remote controller holder		1	Filter holder		2
Cloth tape		1	Air cleaning filters		1
Wall hook bracket		1			

■ **Models: ASYG07KETA, ASYG09KETA, ASYG12KETA, ASYG14KETA, ASYG07KETA-B, ASYG09KETA-B, ASYG12KETA-B, and ASYG14KETA-B**

Part name	Exterior	Q'ty	Part name	Exterior	Q'ty
Operating manual		1	Cloth tape		1
Operating manual (CD-ROM)		1	Tapping screw (large)		5
Installation manual		1	Tapping screw (small)		2
Remote controller		1	Wall hook bracket		1
Battery		2	Filter holder		2
Remote controller holder		1	Air cleaning filters		1
Template (for pipe cover cutting)		1			



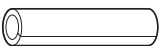

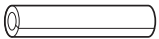

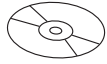

5-5. Ceiling type

■ Model: ABYG18KRTA

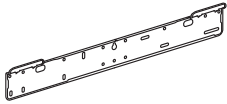
Part name	Exterior	Q'ty	Part name	Exterior	Q'ty
Operating manual		1	Insulation		1
Operating manual (CD-ROM)		1	Drain hose		1
Installation manual		1	Hose band		1
Template		1	Cable tie (large)		4
M10 nut A (with flange)		4	Cable tie (small)		1
M10 nut B (with spring lock washer)		4	Remote controller cable hole cap		1
Washer		8	Tapping screw (White)		6
Coupler heat insulation (large)		1	Tapping screw		3
Coupler heat insulation (small)		1			

5-6. Floor type

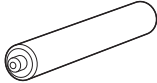
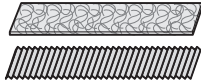
■ Models: AGYG09KVCA, AGYG12KVCA, and AGYG14KVCA

Part name	Exterior	Q'ty	Part name	Exterior	Q'ty
Operating manual		1	Operating manual (CD-ROM)		1
Installation manual		1	Cloth tape		1
Wall hook bracket		1	Tapping screws (large)		9
Remote controller		1	Tapping screws (small)		2
Battery		2	Air cleaning filters		1
Remote controller holder		1			

5-7. Outdoor unit

■ Model: AOYG18KBTA3

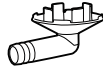
Part name	Exterior	Q'ty	Part name	Exterior	Q'ty
Installation manual		1	Drain pipe		1

■ Model: AOYG24KBTA3

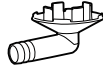
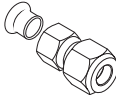
Part name	Exterior	Q'ty	Part name	Exterior	Q'ty
Installation manual		1	Drain pipe		1
Adapter K: mm (in) 12.70 (1/2) to 9.52 (3/8)		1			

6. Refrigerant system diagrams

6-1. Models: AOYG18KBTA3 and AOYG24KBTA3

TECHNICAL DATA
AND PARTS LIST

TECHNICAL DATA
AND PARTS LIST

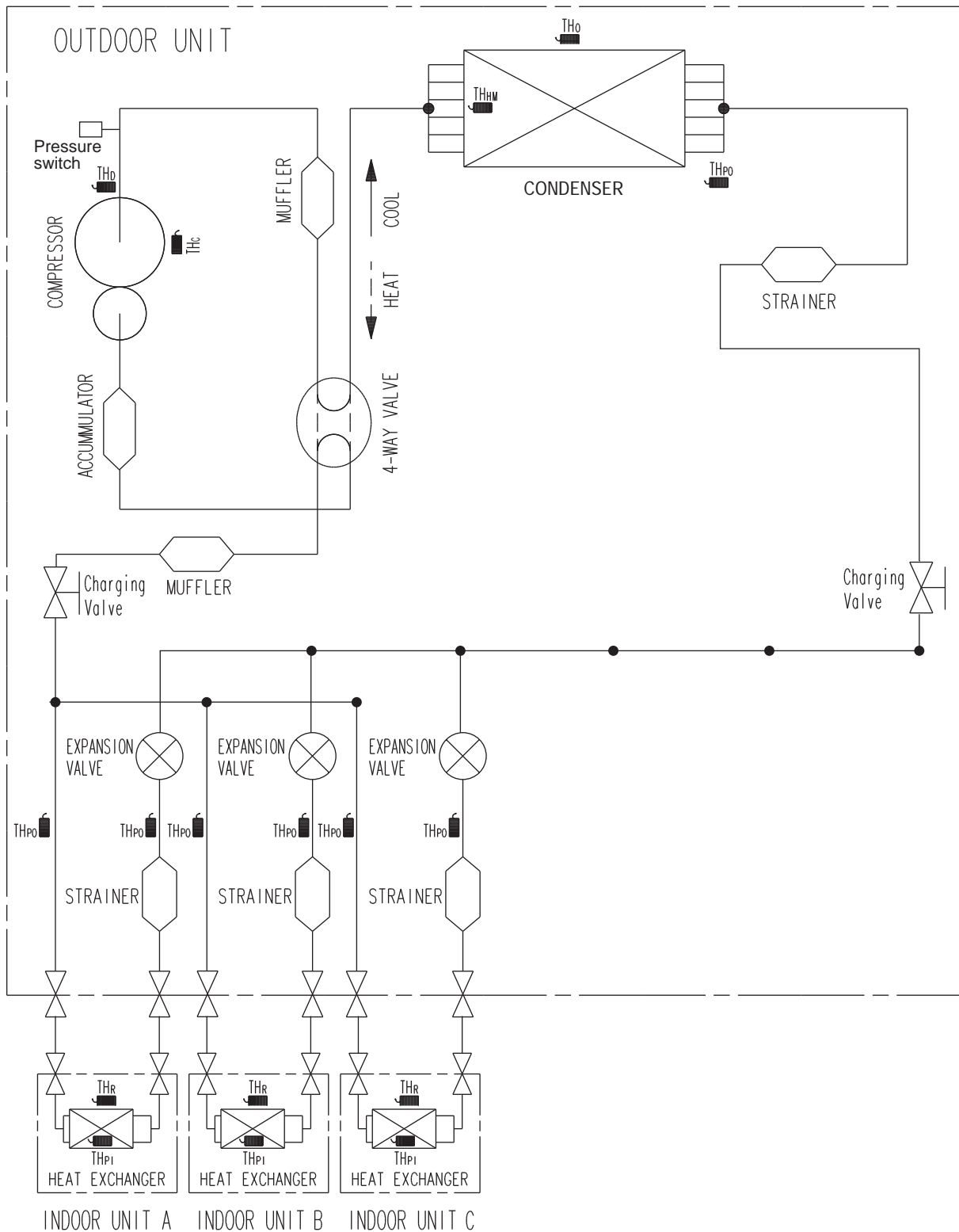

TH_o : THERMISTOR(DISCHARGE TEMP.)
 TH_o : THERMISTOR(OUTDOOR TEMP.)
 TH_{po} : THERMISTOR(PIPE TEMP.)
 TH_c : THERMISTOR(COMPRESSOR TEMP.)

TH_r : THERMISTOR(ROOM TEMP.)
 TH_{p1} : THERMISTOR(PIPE TEMP.)
 TH_M : THERMISTOR(HEAT EXCHANGER MIDDLE TEMP.)

7. Wiring diagrams

7-1. Compact cassette type

■ Models: AUXG07KVLA, AUXG09KVLA, AUXG12KVLA, AUXG14KVLA, and AUXG18KVLA

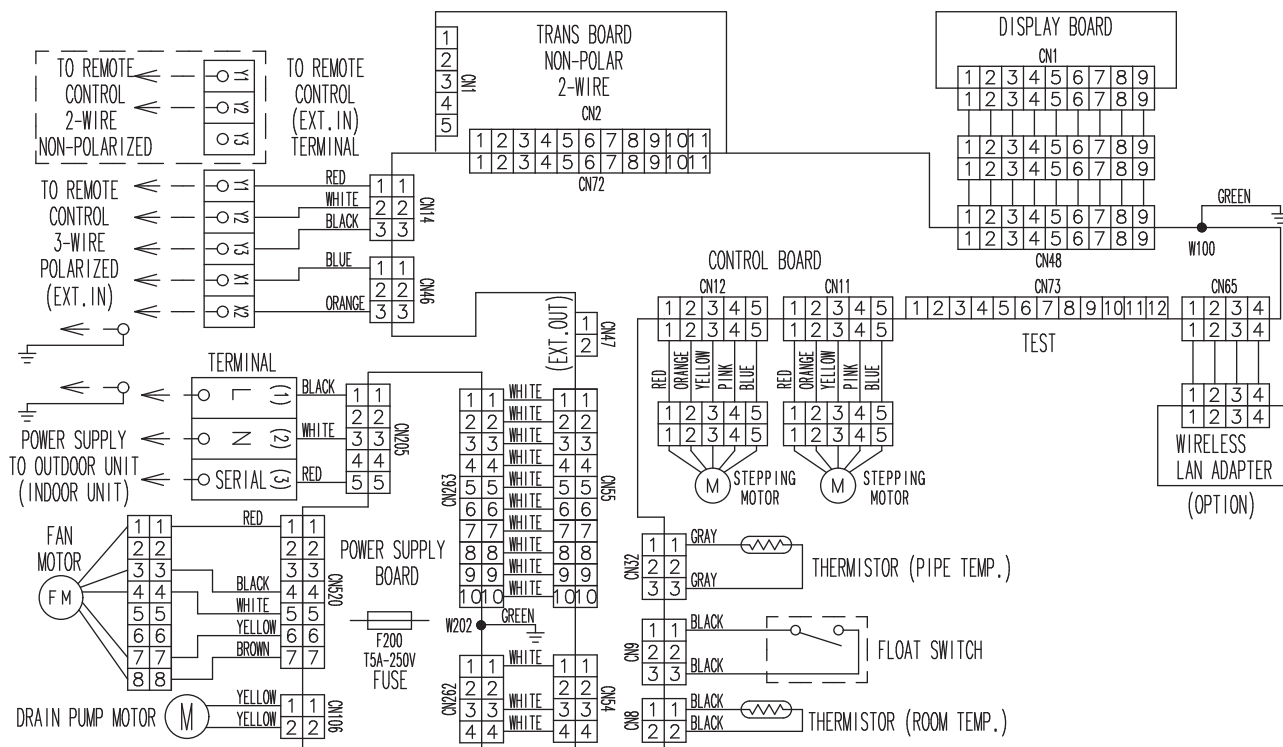

TECHNICAL DATA AND PARTS LIST

TECHNICAL DATA AND PARTS LIST

7-2. Mini duct type and Slim duct type

- Models: ARXG07KSLAP, ARXG09KSLAP, ARXG12KSLAP, ARXG14KSLAP, ARXG18KSLAP, ARXG07KLLAP, ARXG09KLLAP, ARXG12KLLAP, ARXG14KLLAP, and ARXG18KLLAP

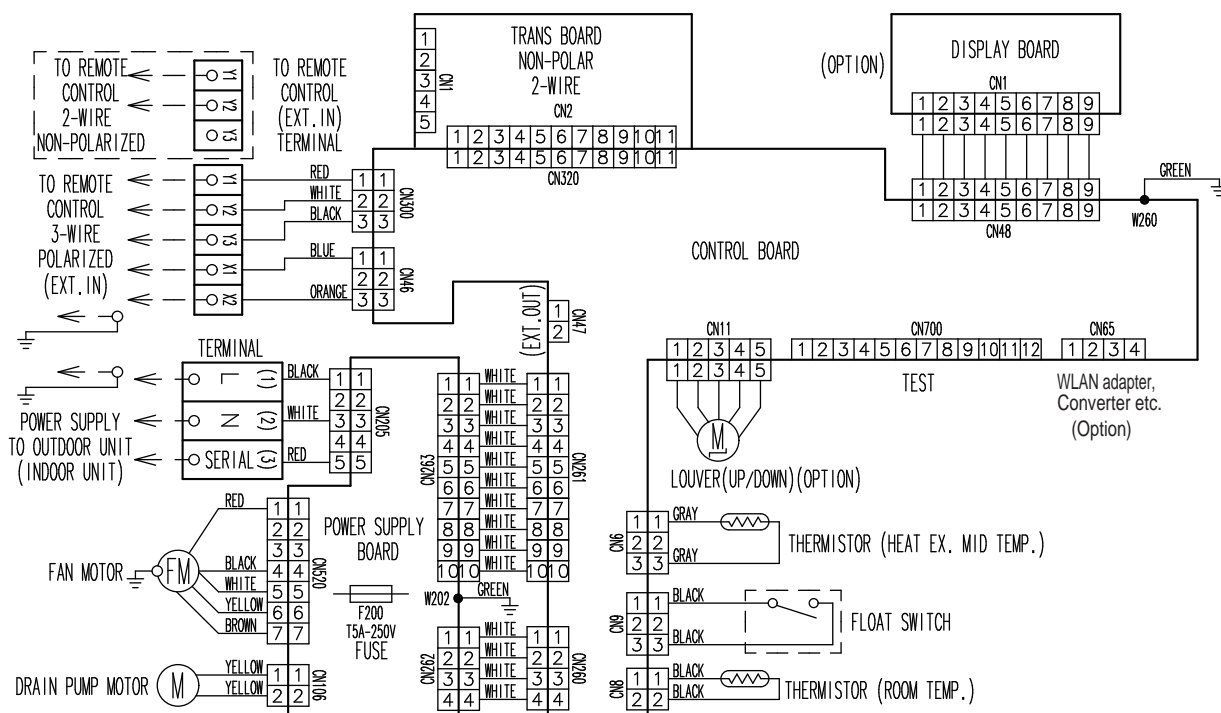

TECHNICAL DATA AND PARTS LIST

TECHNICAL DATA AND PARTS LIST

7-3. Wall mounted type

Models: ASYG07KGTB, ASYG09KGTB, ASYG12KGTB, and ASYG14KGTB

TECHNICAL DATA AND PARTS LIST

TECHNICAL DATA AND PARTS LIST

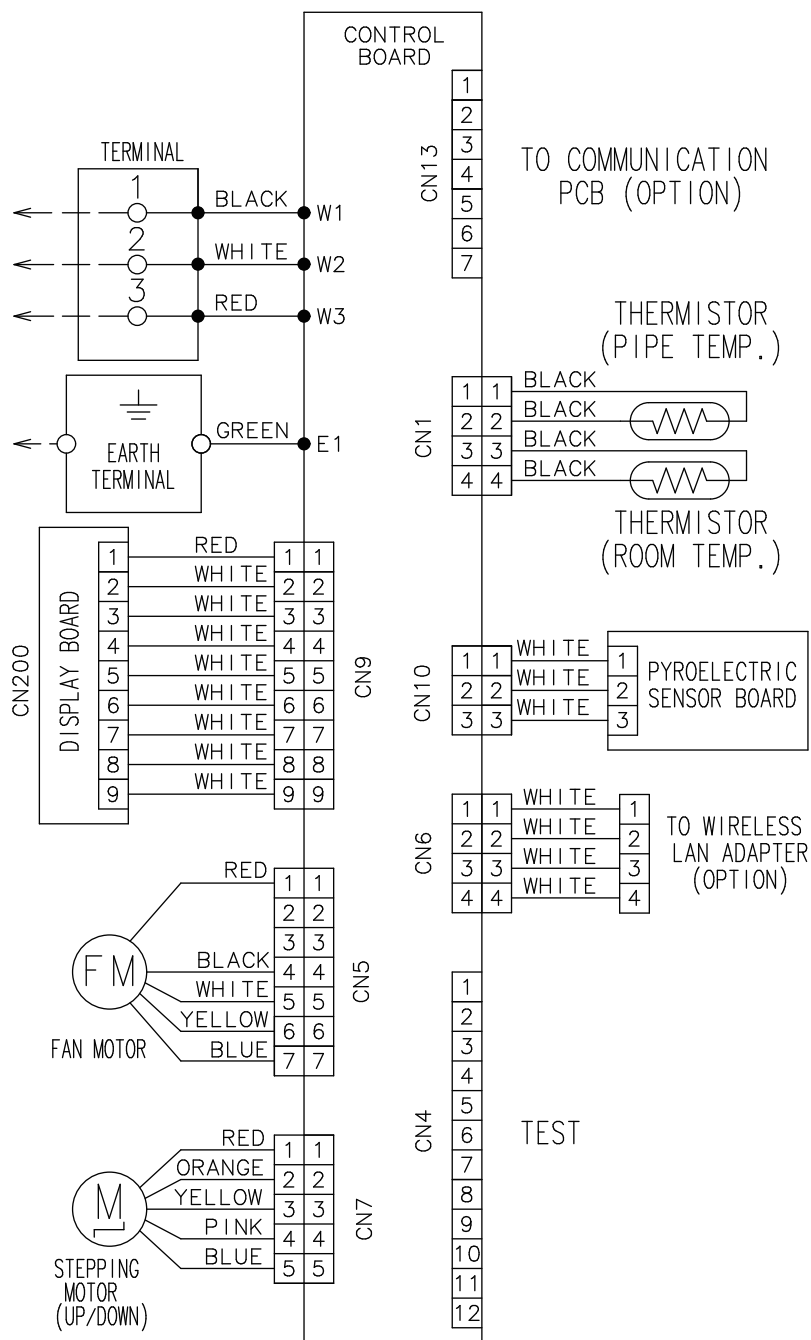

Model: ASYG18KMTB

TECHNICAL DATA
AND PARTS LIST

TECHNICAL DATA
AND PARTS LIST

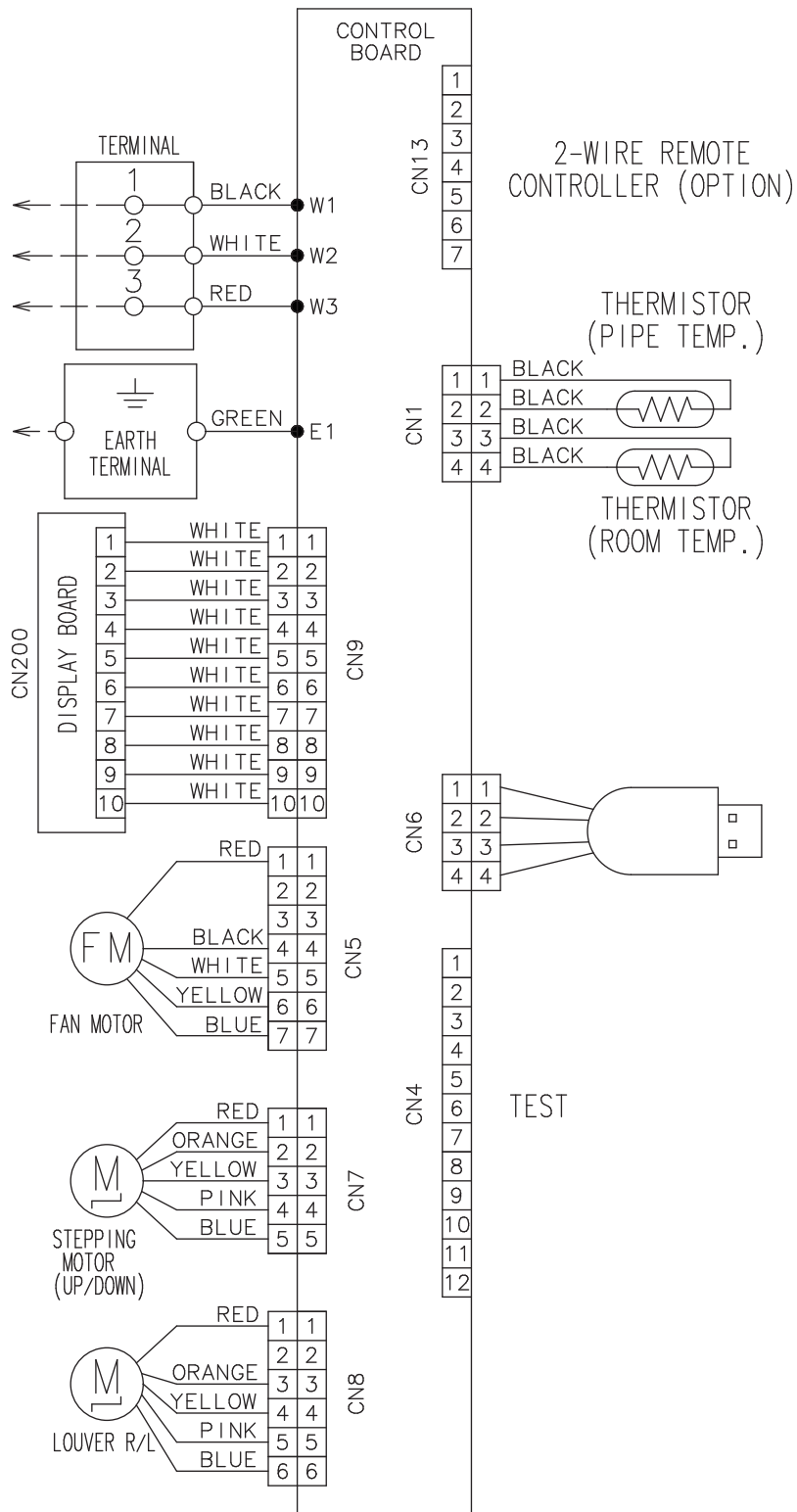

Models: ASYG07KMCC, ASYG09KMCC, ASYG12KMCC, and ASYG14KMCC

TECHNICAL DATA
AND PARTS LIST

TECHNICAL DATA
AND PARTS LIST

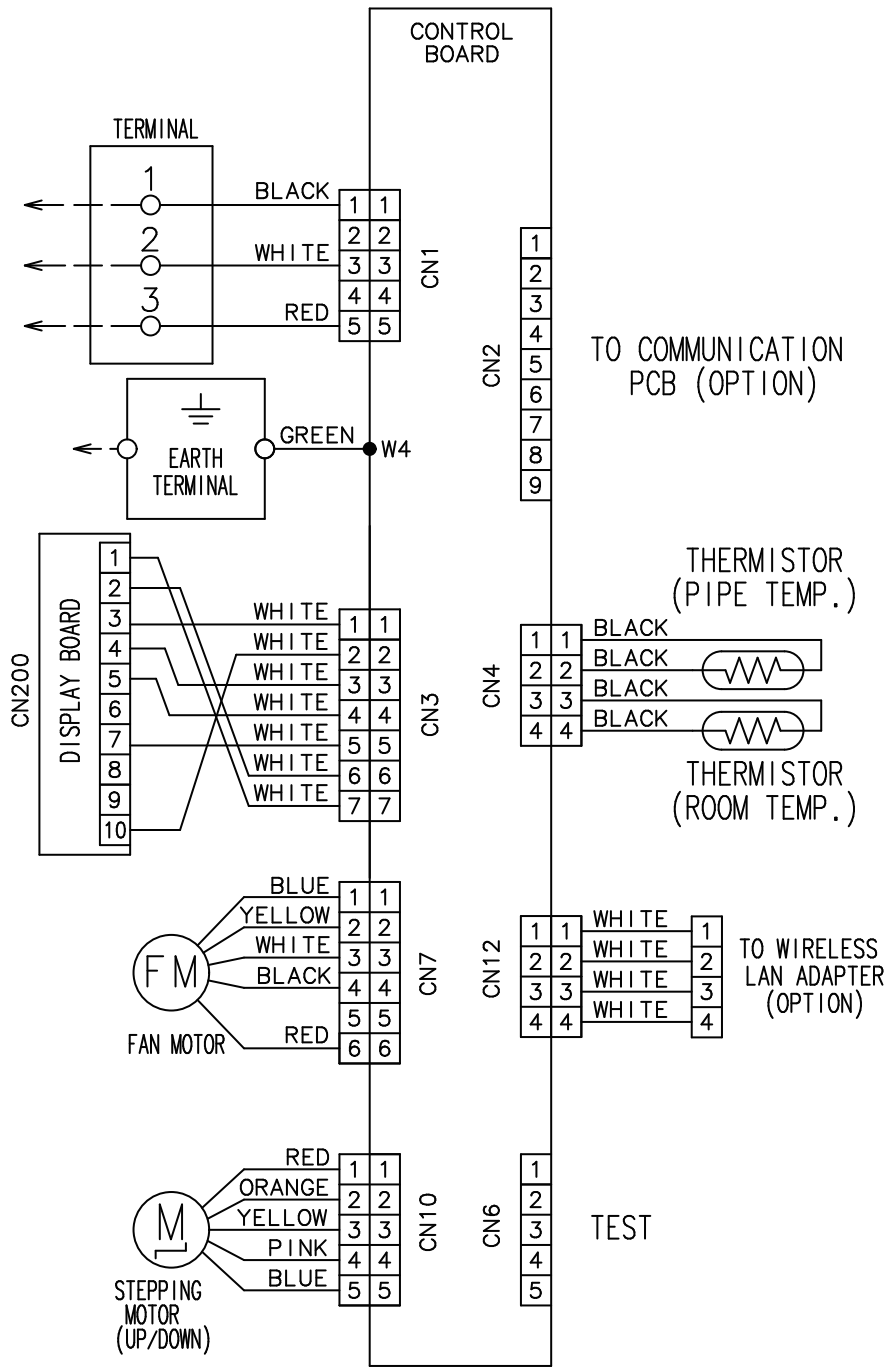

■ Models: ASYG07KETA, ASYG09KETA, ASYG12KETA, ASYG14KETA, ASYG07KETA-B, ASYG09KETA-B, ASYG12KETA-B, and ASYG14KETA-B

TECHNICAL DATA
AND PARTS LIST

TECHNICAL DATA
AND PARTS LIST

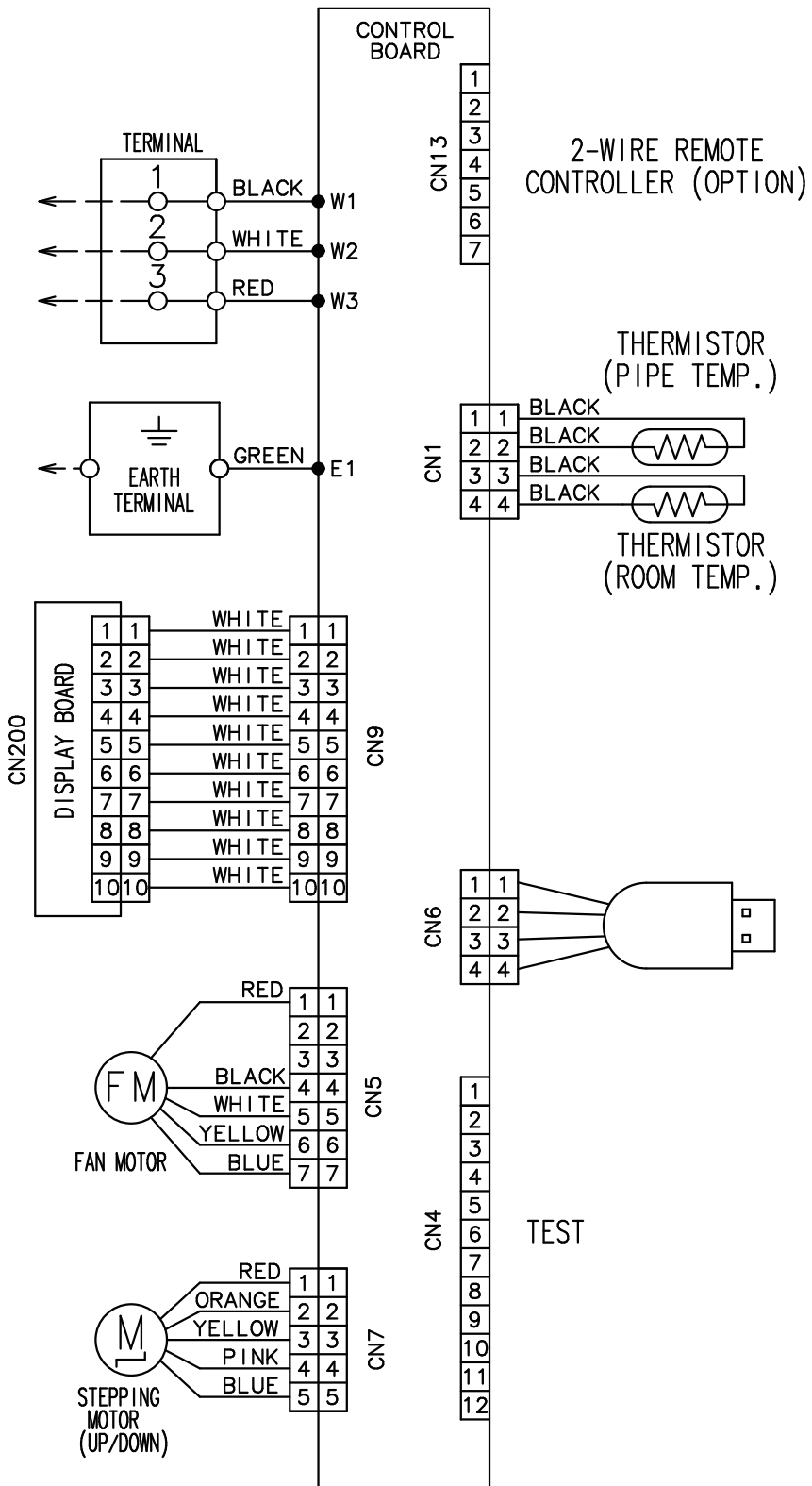

7-4. Ceiling type

Model: ABYG18KRTA

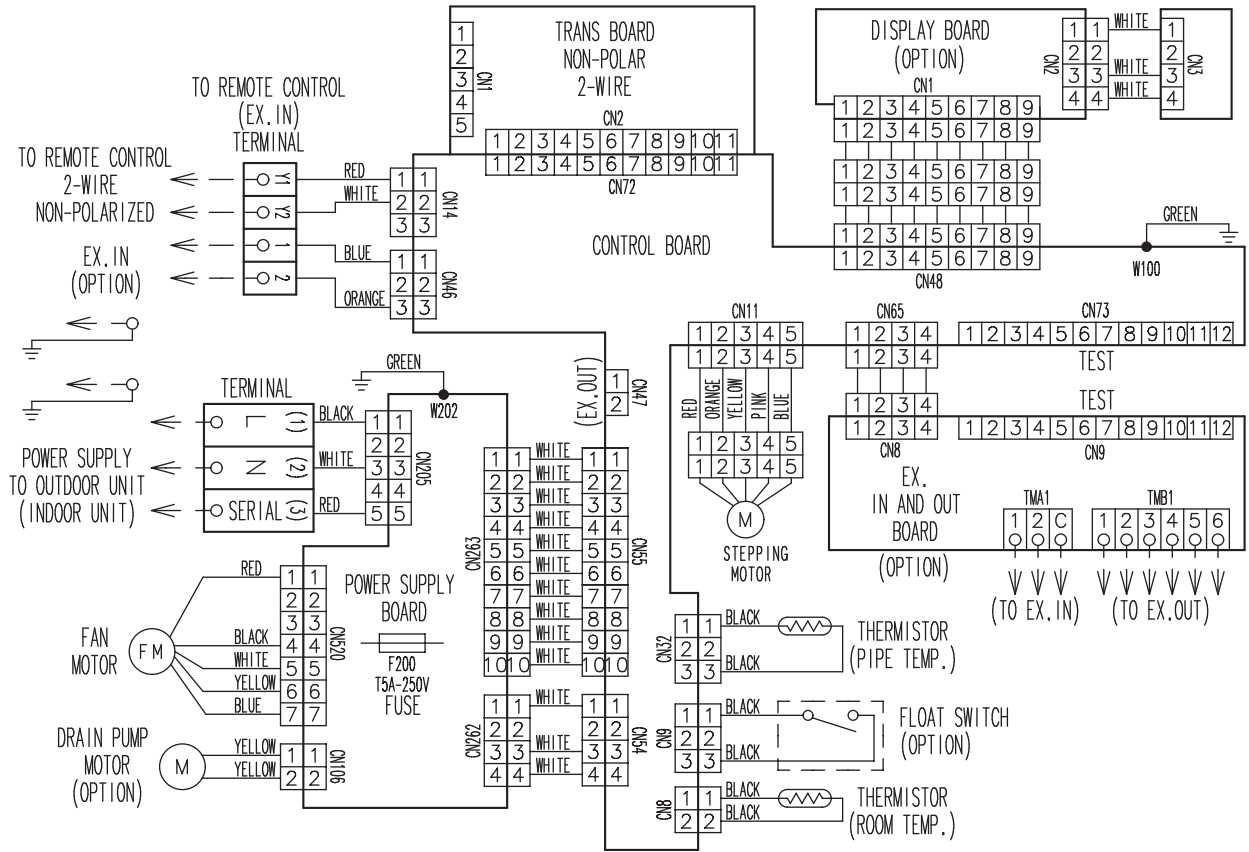

TECHNICAL DATA
AND PARTS LIST

TECHNICAL DATA
AND PARTS LIST

7-5. Floor type

Models: AGYG09KVCA, AGYG12KVCA, and AGYG14KVCA

TECHNICAL DATA
AND PARTS LIST

TECHNICAL DATA
AND PARTS LIST

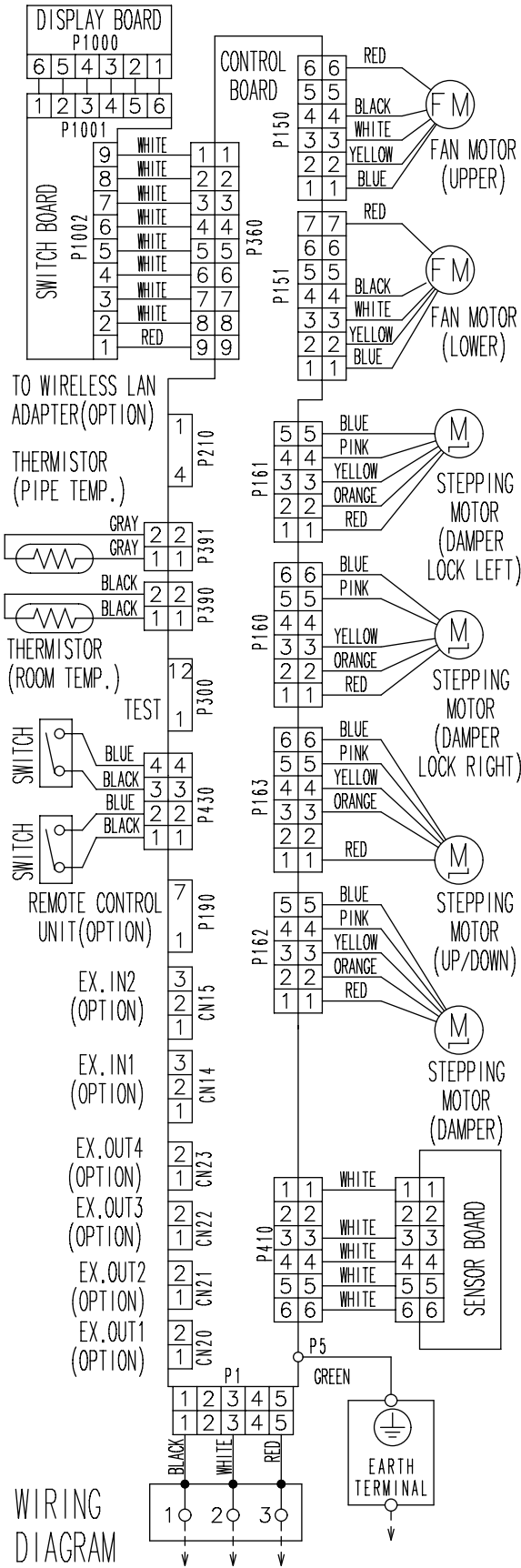

7-6. Outdoor unit

Models: AOYG18KBT A3 and AOYG24KBT A3

TECHNICAL DATA AND PARTS LIST

TECHNICAL DATA AND PARTS LIST

