



## Photo



## Descriptions

- Integrate the signal receiver in the corner panel (the opposite side of refrigerant piping).
- Applicable only for PLA-A\*\*BA,BA1 models.

## Applicable Models

- PLA-A\*\*BA/BA1

## Specifications

Model name	PAR-SA9FA-E
Operation indicator lamp	During operation: LED (green) lights, Abnormal condition: LED (green) blinks, Preparing for heating operation:LED.(orange) lights
Emergency operation	Cooling/heating switch (operate/stop) equipped.
Number of controllable units	Maximum 16 refrigerant systems in one group (At least one wireless signal receiving kit must be installed to each refrigerant system.)
Adapter wiring	Connect the 9-core cord with connector (attached) to CN90 of the indoor controller board of the indoor unit.
Signal distance	Within 7m in 45 degrees range from the front of the signal receiver

## Dimensions

Unit : mm

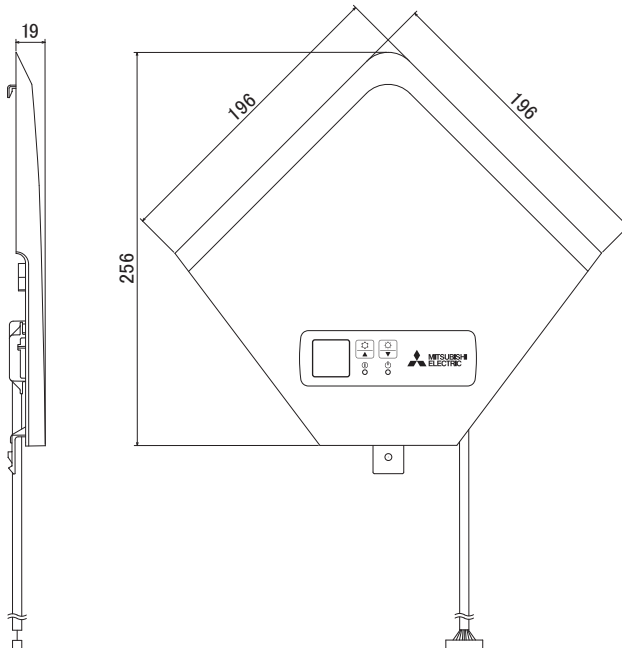

OPTIONAL PARTS

# How to Use / How to Install

## 1 Before installation ※Turn off the main power before work.

- Open the intake grill and remove the corner panel where refrigerant pipes are and where local wires are drawn into.
  - ※ The corner panel removed is not needed.
  - ※ When attaching the duct flange during installation of decoration panel, perform the following work only after connecting the wires to the decoration panel:
- The control box cover fixed by 3 screws, which is possible to hang temporarily.
- Perform setting to designate the unit to be operated by the wireless remote control.
  - Set J41 and J42 (jumper wires) on the indoor controller board and pair number switch of the wireless remote control as follows:
- Setting pair number
  - Up to 4 patterns of pair number can be set. Match the pair number (setting of J41 and J42) of the indoor controller board and the pair number switch of wireless remote control as shown in the table below.
  - ※ See the installation manual provided with the wireless remote control for details on setting method of the wireless remote control.

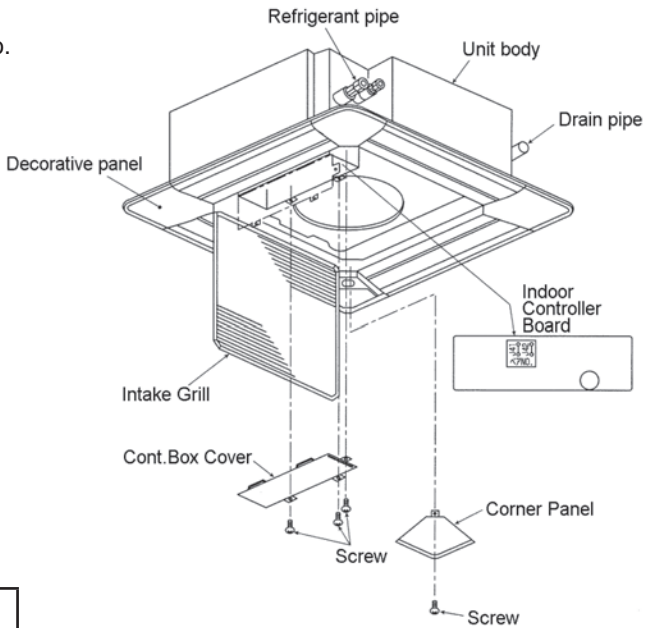

Setting Pattern.	Pair number of wireless remote controller.	Cut point of Jumper wires on the indoor controller board.
A	0	Don't cut the jumper wire
B	1	Cut the jumper wire "J41"
C	2	Cut the jumper wire "J42"
D	One of procedures 3-9	Cut the jumper wire both "J41" and "J42"

## 2 Installation of signal receiving unit.

- Pull out the cable of infrared receiver from the square hole in the corner of decoration panel, the portion of corner panel that was removed in step 1.
- Pass the cable through the three hooking portions of unit and electrical parts box as shown in the figure, adjust the length of cable so that the
- Slide the receiving unit in the ① direction as shown and fix it by the screw which is used for the corner panel removed.

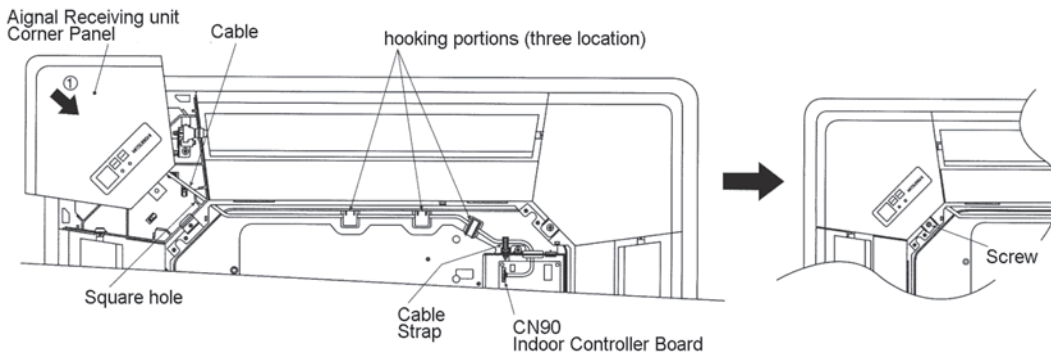

- After the installation completed, set the cont,box cover as they were.